



# VALLOX 75.95

• 1.09.292E  
• 13.02.07  
© VALLOX

Type: 3510

## Supply and extract air ventilation with heat recovery

For blocks of flats, terraced houses  
and detached houses.



**INSTRUCTIONS FOR USE AND MAINTENANCE**



# VALLOX 75/95

## MAIN PARTS

### EVERYDAY QUICK GUIDE

VALLOX 75/95 has been initially adjusted for normal circumstances in your home.

Ventilation adjustment is needed mainly in the following circumstances:

#### • Taking a bath

Boost ventilation in bathing and washing facilities in order to ensure that the rooms get dry as quickly as possible. It is recommended to have boosted ventilation on for 2 to 3 hours after taking a sauna bath.



#### • Washing and drying clothes

Boost ventilation in washing and drying facilities during these activities.



#### • Sleeping

Ventilation in a bedroom has to be sufficient throughout the night. The level is correct when air does not smell fusty when you enter the room in the morning.



#### • Empty dwelling

To save energy, ventilation can be adjusted to the minimum level.



#### • Cooking

When the ventilation unit is integrated with a cooker hood, boost ventilation while cooking food (the most common way in blocks of flats to abate cooking fumes). Small detached houses and terraced houses are normally equipped with a separate cooker hood.



### VALLOX 75/95

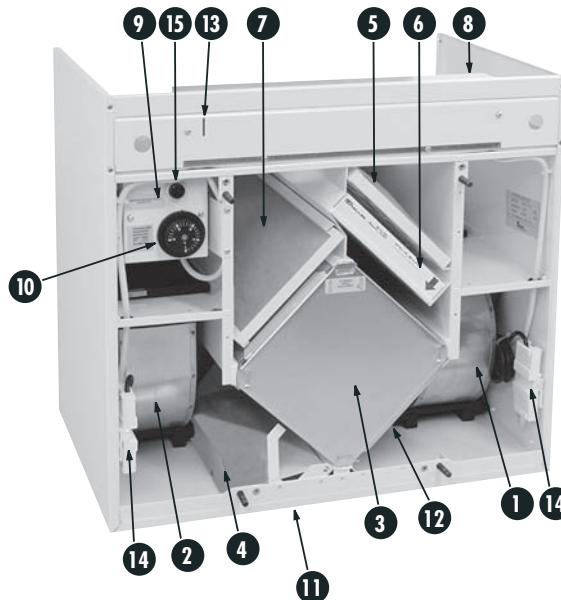

- |  |  |
|--|--|
| 1. Extract air fan<br>VALLOX 75 105 W<br>VALLOX 95 180 W | 6. Outdoor air fine filter F7  |
| 2. Supply air fan<br>VALLOX 75 105 W<br>VALLOX 95 180 W  | 7. Extract air coarse filter G3  |
| 3. Heat recovery cell                                    | 8. Electrical connection box   |
| 4. Damper for summer/<br>winter ventilation              | 9. Post-heating radiator 500 W (in picture)<br>or, in VKL models, water radiator |
| 5. Outdoor air coarse filter G3                          | 10. Post-heating radiator regulating thermostat                                  |
|  | 11. Condensing water outlet (below the unit)                                     |
|  | 12. Cell antifreezing sensor   |
|  | 13. Safety switch  |
|  | 14. Electrical quick-connect terminal for fans                                   |
|  | 15. Overheat protection reset button   |

### THREE QUESTIONS ABOUT VENTILATION

#### Why is air replaced in dwellings?

**Good ventilation promotes healthy living for both residents and the building.** Air in a dwelling needs to be replaced in order to remove humidity brought about by living and impurities emanating from structures and human bodies. Impurities of indoor air include carbon dioxide, formaldehyde, radon and other gases as well as dust.

Mechanical ventilation is needed for adjusting air circulation as needed by the residents. In a well sealed house, air does not circulate sufficiently by natural means. Even in a poorly sealed house air is only replaced because of differences between indoor and outdoor air temperatures, or because of winds. This means that ventilation is dependent on weather conditions and cannot be regulated.

It is especially important that humidity and carbon dioxide content of the indoor air stay at a healthy level. Recommended humidity content of good indoor air is approximately 45%. Humidity content is lower in winter and higher in summer and autumn. Dust mites thrive in indoor air if humidity exceeds 50%, and if humidity stays at over 60% for a long time in winter, water condenses in the cold structures of the house and mould starts to form.

The recommended maximum carbon dioxide content in good indoor air is circa 1,000 ppm.

#### What are the characteristics of adequate ventilation?

- Indoor air stays fresh in all the rooms of the dwelling, also in bedrooms during night.  
**Without adequate ventilation**, carbon dioxide content tends to rise high especially in bedrooms.
- The bathroom and the sauna get dry quickly.
- During the heating season, the windows and other outer wall structures remain dry.
- Humidity in indoor air is not condensed in the ventilation ducts.
- Air is fresh in the toilet as well.

#### How much air is replaced?

For air to be clean to breathe, it has to be replaced with outdoor air **every two hours**. In a new and a renovated house, air circulation needs to be boosted during the first year in order to remove harmful gases and structural humidity. In buildings that are more than a year old and dry, ventilation can be regulated as needed. Ventilation is boosted during for instance a sauna bath, clothes washing and cooking, and reduced during very cold periods or when there is nobody at home.

#### Window ventilation

Dwelling-specific supply / extract air circulation does by no means prevent you from opening windows and the door to the balcony or airing through them.

In window or door ventilation attention needs to be paid to the following factors:

During the heating season window ventilation consumes, uncontrollably, a considerable amount of energy.

An open window lets in dusty and dirty air.

An open window also lets in noise pollution.

### SEASONAL CALENDAR



#### Autumn

- Wash or change the coarse filter and clean or change the fine filter if needed.
- Check that the heat recovery cell is clean.
- Check that the condensing water outlet is not clogged.



#### Spring

- Wash or change the coarse filter and clean or change the fine filter if needed.
- Clean the fan blades and the post-heating unit if needed.
- Check that summer ventilation is in operation.

#### NOTE!

For further details, see inner pages.



# VALLOX 75/95

## VENTILATION SYSTEM



### WARNING

Shutting down ventilation in the dwelling also prevents the inflow of new fresh outdoor air to the dwelling and the outflow of dirty air and impurities emanating from human bodies, structures and the soil, such as carbon dioxide, humidity, odours, formaldehyde, dust and radon.

These impurities quickly spoil indoor air and cause health problems, whereas excessive humidity may spoil structures and cause mould and fungus growth. Therefore, the building regulations require ventilation to be continually in operation and the level of ventilation to be adjusted as needed by the user.

As the name says, a dwelling-specific ventilation system (blocks of flats, terraced houses, small detached houses) is meant for only one dwelling.

The system includes two sides. The extract air side takes dirty and humid air out, while the supply air side brings a corresponding amount of outdoor air in.

Ventilation in the rooms is continual and can be regulated as needed. Outdoor air is mainly brought to the bedrooms, sitting room, fireplace room, dining room and sauna. From these rooms supply air can flow freely, for instance through door vents, to the bathroom, sauna, toilet, walk-in closet, kitchen and other rooms with air vents. If cold outside air can be let in to the sauna, only use it when it is needed as combustion air for a wood-heated sauna oven.

The resident may regulate the power of ventilation (air circulation) as needed.

### Filtering

Outdoor air is filtered before taking it in to the dwelling. A coarse filter first removes the biggest litter particles, thereby preventing the system from getting dirty. After that air passes through a fine filter, which catches finer dust and even the smallest pollen particles.

### Filter guard (option)

An optional filter guard for the unit monitors the cleanliness of the unit and the filters. The setpoint of the filter guard is set individually for each dwelling so that the filter guard indicator lights up at fan speed 3 or 4 when the filters are clean .

### Heating of outdoor air

During the heating season, heat included in extract air is used to heat air coming from the outside. Heat is transferred in the heat recovery cell through laminas, and extract air never mixes with air coming inside. This may provide all the heating needed. The ventilation units are, however, equipped with a post-heating radiator, which can be used to warm air if more heating is needed.

Filter guard indicator lamp

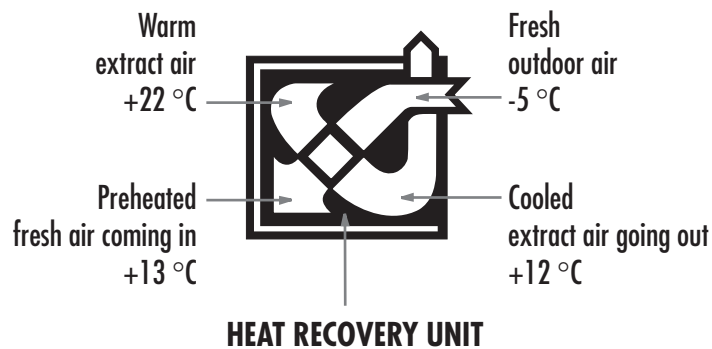

### Winter and frosts

When temperature in winter falls below  $-10\text{...}-20\text{ }^{\circ}\text{C}$ , the intake of outdoor air is limited by stopping the supply air fan. This prevents the water condensing in the unit from extract air from freezing.

For indoor air to stay healthy and beneficial also for the structures of the dwelling, ventilation has to be in operation continually. It is not advisable to stop ventilation even for longer holidays, because it makes indoor air stuffy. Also, during the heating season indoor air humidity may condense in the ducts and structures and therefore cause humidity damage.



### Initial adjustment

The ventilation system works properly when air flows in the rooms have been measured and adjusted with the valves in accordance with the planned values. **After the initial adjustment, the position of the ventilation valves must not be changed.** If there is an outlet valve with a knob in the ceiling of the sauna, it can be adjusted as needed. The initial adjustment ensures that a sufficient amount of air is circulated and that extract air flow is always greater than supply air flow, i.e. the dwelling is negatively pressured compared to outdoor air. If the dwelling is positively pressured, air in the dwelling penetrates the outer envelope of the building and between windows, which may cause humidity damage during the heating season.

In normal conditions **basic ventilation** with change of air every two hours is sufficient in living areas. Boosting is needed during for example sauna baths, cooking, clothes washing or family parties.

If the user does not know the measured air flows, the adjacent table shows approximate extract air flows as well as the total electricity consumption of the fans at various fan speeds. The table also shows the fan speed that is sufficient for recommended basic ventilation in dwellings of different sizes.

The switch positions, i.e. fan speeds, displayed in the table on a darker background are factory preset values. If needed, an expert or electrician can change (or has changed during the initial adjustment) settings and select speeds shown on a white background instead. Voltage changes are also made by an expert, not the user himself.

### VALLOX 75 (105 W fan)

SWITCH POSITION	1	1.1	2	2.1	3	3.1	4
	70 V	90 V	120 V	135 V	160 V	180 V	230 V
Living area (m <sup>2</sup> )	30	45	85	110	140	150	200
Air flow (dm <sup>3</sup> /s)	15	20	30	40	50	55	70
Total electricity consumption of fans (W)	25	38	63	78	104	128	182

### VALLOX 95 (180 W fan)

SWITCH POSITION	1	1.1	2	2.1	3	3.1	4
	70 V	90 V	120 V	135 V	160 V	180 V	230 V
Living area (m <sup>2</sup> )	40	70	140	150	200	210	240
Air flow (dm <sup>3</sup> /s)	20	30	50	55	70	75	85
Total electricity consumption of fans (W)	40	63	103	124	158	183	225





# VALLOX 75/95

## INSTRUCTIONS FOR USE



The table on the preceding page indicates rated speeds and air flows for dwellings of different sizes.

The table also indicates the total electricity consumption of the fans at each speed.



Cooker hood LTX



Control centre with a separate switch

### Adjustment of the power of ventilation

VALLOX 75 and VALLOX 95 ventilation units can be controlled with either a cooker hood or a separate control centre.

#### Cooker hood control

The cooker hood is connected to the ventilation unit and is used to control air circulation in the whole dwelling. Four power ranges are available.

##### Speed 1.

Use during absence. When the dwelling is empty, ventilation can temporarily be diminished.

##### Speeds 2 and 3.

These are speeds that are normally used.

Speed 2 is used when the need of ventilation is fairly small and air is good.

Speed 3 is used when there is a need for boosting, for instance in the following situations: cooking, taking a sauna bath, drying clothes, use of toilet, guests, excess heat and "large dwellings".

##### Speed 4.

This boosting position is used as needed, for example during cooking, parties and hot weathers.

##### Cooking

Open the flap of the cooker hood during cooking. At other times, the flap must be kept closed. An open flap decreases the power of ventilation in other rooms.

There are different kinds of cooker hoods. For more details, see the instructions of the hood in question.



#### Separate cooker hood (most often in detached houses)

If there is a cooker hood independent of the ventilation system in the dwelling, only use it when needed. Using it does not affect the operation of the ventilation unit, because the unit replaces air in other rooms. There is in this case minor ventilation in the kitchen connected to the ventilation unit. The unit is controlled with a separate control centre.

#### Separate control centre

The regulator (switch) is only used to control the ventilation unit. There are four power ranges available.

##### Speed 1.

Use during absence. When the dwelling is empty, ventilation can temporarily be diminished.

##### Speeds 2 and 3.

These are speeds that are normally used.

Speed 2 is used when the need of ventilation is fairly small and air is good.

Speed 3 is used when there is a need for boosting – for instance in the following situations: cooking, taking a sauna bath, drying clothes, use of toilet, guests, excess heat and "large dwellings".

##### Speed 4.

Boosting position, used as needed for example during cooking, parties and hot weathers.

##### Cooking

Cooking fumes are taken out with a cooker hood or an integrated hood and ventilator.

For more instructions, see the instructions of the equipment in question.

Detailed instructions for special control centres are available.



## INSTRUCTIONS FOR USE

### Example: Warming of outdoor air in the HR cell with electric radiator

- Curve 1 Temperature of the air coming from the unit to the dwelling at different outdoor temperatures when the post-heating radiator is not on.
- Curve 2 Supply air temperature controlled by the thermostat of the electric radiator, adjustment value 23 °C (air flow less than 38 dm<sup>3</sup>/s)
- Curve 3 500 W post-heating resistor can heat 50 dm<sup>3</sup>/s flowing air by about 8 °C.
- Curve 4 Supply air temperature with water radiator, water +25 °C and flow 0.05 dm<sup>3</sup>/s.
- Curve 5 Supply air temperature with water radiator, water +45 °C and flow 0.05 dm<sup>3</sup>/s.

Because heat release of water radiator is dependent on many factors, the curves are approximate. Glycol decreases radiator power with 10...20 % depending on mixture.

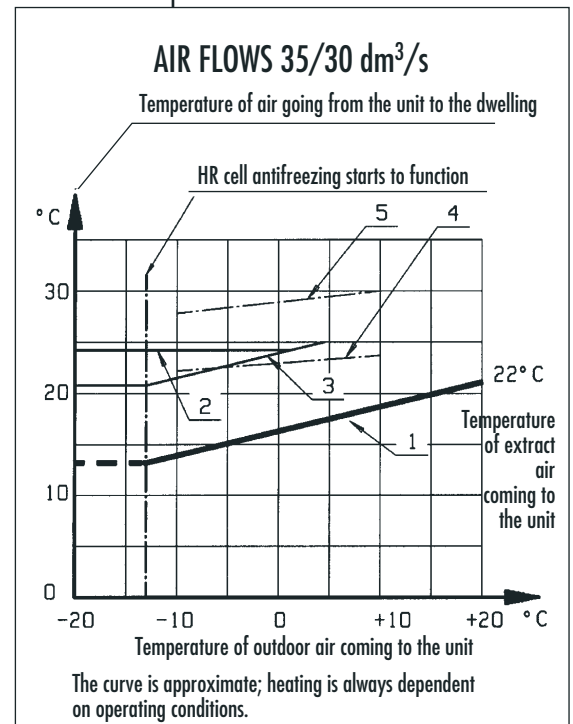

### Post-heating

For most of the year, heat recovered from air to be extracted is enough to warm the cold air coming from the outside to a suitable temperature. If the heat of extract air is not enough, air coming from the outside may be heated further with the radiator delivered with the unit.

### Post-heating with electric radiator

VALLOX 75 and VALLOX 95 come standard with a 500 W electric radiator for heating supply air. The temperature of supply air is adjusted at the thermostat regulator located inside the unit. Adjustment range of temperature is approximately +0...+25 °C.

It is advisable to set the thermostat at 0 °C in summer. In this case, the radiator does not heat air, as the heat recovery cell is bypassed.

### Post-heating with water radiator (VKL model)

VKL models come standard with a water radiator (P). Temperature of air going from the unit is adjusted with the controller of self-actuated thermostat valve (T).

### Water radiator defrosting

The defrost thermostat (T) of the post-heating radiator (P) stops the unit when the temperature of water radiator goes below the threshold value, preventing the risk of freezing in the water radiator. This also causes self-actuated one-way dampers (Y) to close, preventing the flow of outdoor air to the unit. The unit starts automatically as soon as the risk of freezing has passed. The threshold temperature of the risk of freezing can be set at the thermostat (T).

### WARNING!

Though VALLOX 75 / 95 VKL units have an efficient freezing protection for the radiator, there is always a risk of freezing in the radiator unless non-freezing heat transfer solution is used. If the unit stops altogether (extract and supply air fan) in winter, the cause must be defined in order to prevent heat transfer solution (water) from freezing. In winter the automatic defrost function of the heat recovery cell keeps stopping the supply air fan; this is normal.

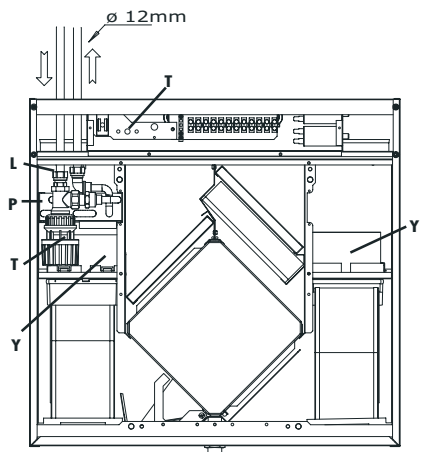
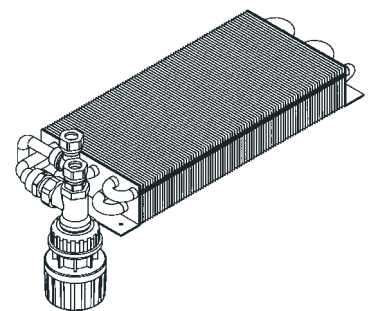
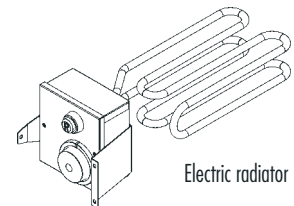



# VALLOX 75/95

## INSTRUCTIONS FOR USE

### SUMMER/WINTER VENTILATION

#### In winter use

the heat recovery cell of VALLOX 75 and VALLOX 95 recovers heat from the air leaving the dwelling and uses it to heat the air coming from the outside. The damper is in down position.

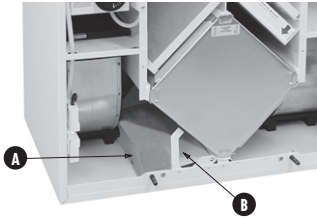

#### In summer use

when it is warm outside, it is unnecessary to heat outdoor air. The heat recovery cells are then bypassed with the damper (A) coming standard with the unit. The damper is lifted up and locked with a lock (B). In the summer position air flow through the cell is prevented, and heat recovery bypass is activated. In summer set the electric post-heating thermostat at 0 °C position so that the radiator will not heat. If needed, the setpoint value of the water radiator thermostat shall also be reduced.

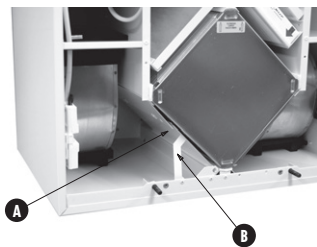

### Defrosting

Water condensing from extract air may freeze in the heat recovery cell. Freezing can be prevented by stopping the supply air fan (standard function). The VKL model also includes a water radiator defrost thermostat, which stops both fans when there is a risk of freezing in the radiator.

### Stopping of supply air fan

The defrost thermostat stops the supply air fan whenever the temperature of exhaust air goes down to circa +4 °C. The fan restarts when temperature has risen by three degrees, i.e. to 7 °C. The threshold value of the thermostat can be adjusted. The function starts at the outdoor temperature of about -10...-15 °C.





## MAINTENANCE INSTRUCTIONS

In blocks of flats and terraced houses, the maintenance of the unit is taken care of by a property maintenance company or the user, depending on the contract.

Before starting maintenance activities, stop the machine either at the ON/OFF switch or by removing the fuse from the fuse panel of the dwelling. The safety switch also turns the unit off when the door is opened.

### FILTERS

Outdoor air is filtered in the unit with two types of filters. A G3 class coarse filter (A) filters off insects, heavy pollen and other dust. A F7 class fine filter (B) filters off fine, invisible dust. Extract air is filtered with similar G3 class filters as outside air.

Clean the coarse filter (A) when needed for example by washing them 2 to 4 times a year (and more often if needed). Wash a coarse filter with +25...30 °C warm water and washing-up liquid, pressing it smoothly. Do not handle the filters with force. When washing is done properly, filters stand cleaning 4...5 times. In other words, you have to **replace them at least every two years** or when needed.

The fine filter (B) is not washable. Clean it at the same time as the coarse filters, using the brush nozzle of a vacuum cleaner. When cleaning, be careful not to break filter material. **To ensure good supply air quality**, replace the filter from every six months to year (more often if needed) depending on local air quality. It is recommended to replace filters in autumn. This way the filters stay cleaner through the winter and can effectively filter off dust in the following spring.

In connection with the cleaning of the filters, it is also advisable to check the cleanliness of the heat recovery cell (C) every two years or so. Grab the ears at the ends of the cell and pull the cell out of the unit. If the cell is contaminated, soak it in a solution of water and washing-up liquid. Rinse the cell clean with a jet of water. When all the water has drained from between the laminas, push the cell back so that the sealings next to the sliding surfaces are in place and the "up" sticker at the end of the cell points to the corner next to the upper support.

In addition, check in autumn and spring the position of the summer / winter damper and the leaving of condensing water from the unit as well as the position of the post-heating radiator thermostat.

### Filter guard Vallox 75/95 (option)

VALLOX 75/95 can be equipped with an optional filter guard. The filter guard indicator lights up at speeds 3 and 4 when the filters are clean; this is normal and does not call for any maintenance activities. If the indicator does not light up at speed 4, the pressure over the fine filter differs from the factory setting. When needed, an expert may change the setpoint. **If the filter guard symbol already lights up at fan speed 1 or 2, the filters need cleaning.** If they are clean, the lighting up may be caused by a clogged up dense mosquito net installed against mounting instructions in the external grille or by the closing of the supply air valves in the rooms.

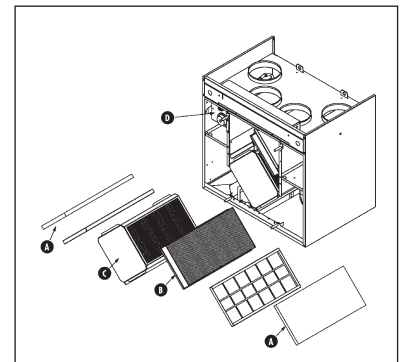
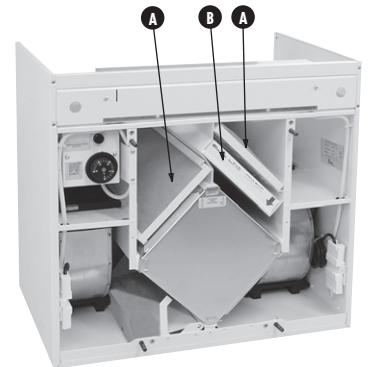

Filters and heat recovery cell.

The units are available in right and left handed models. In the right handed model (model R) outdoor air comes to the unit from the right side of the centre line as shown in the instructions.

In the left handed model (model L) outdoor air comes from the left side of the unit. The filters and the heating radiator (D) change places correspondingly.

### Filter guard indicator lamp





# VALLOX 75/95

## MAINTENANCE INSTRUCTIONS

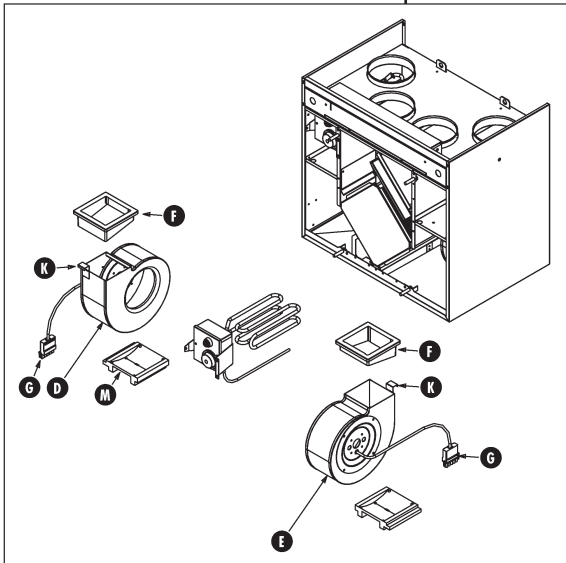

### FANS

The supply and extract air fans (D and E) have been fastened with rubber collars (F). When removing the fans for maintenance, release the ear (K) fixed to the fan over the rubber collar (F) flange by turning the ear to the upright position. Lift the rubber collar out of the opening and turn the fan so that it can be lifted away from the support (M). Remove the plug (G) of the fan.

### Cleaning the fans

Clean the fan blades with compressed air or with brush. Each blade has to be so clean that the fans stay balanced. Take care not to unfasten the balancing pieces attached to the fan blades.

**If you use water in cleaning the unit or its parts, do not let it flow into the electrical parts.**

### CONDENSING WATER

During the heating season, humidity of extract air condenses to water. Water formation may be abundant in new buildings or if ventilation is low compared to the humidity build-up caused by the residents.

Condensing water needs to flow out from the ventilation unit without hindrance. In connection with maintenance, e.g. in autumn before the beginning of the heating season, make sure that the condensing water outlet in the bottom reservoir is not clogged. You may check it by pouring a little water in the reservoir.

**Do not let water flow into electrical devices.**

### OTHER CLEANING

In connection with maintenance, also check the inner surface of the unit and the condensing water reservoir. If they are dirty, clean them gently with a damp cloth, brush, vacuum cleaner or similar. Keep the unit clean to ensure its flawless operation and hygiene.

## Thermostat part and one-way damper in the VKL model

### Unfastening and fastening of the thermostat part of the self-actuated valve

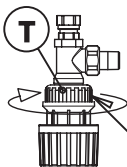

Thermostat sensor has been unlocked. Detach the sensor by turning the collar to the direction shown by the arrow.

When remounting the sensor, turn the collar to the direction shown by the arrow to make the claws lock in the open position, check that the green indicator dot is visible and push the thermostat sensor to attach it to the body of the valve.

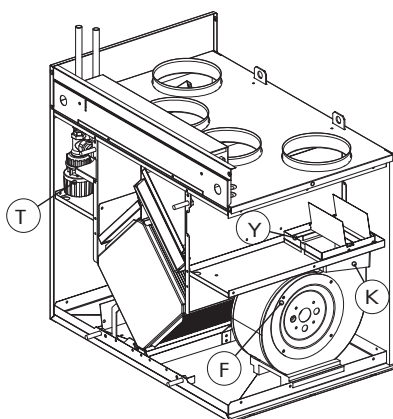

### Unfastening and fastening of the self-actuated one-way damper (vacuum damper)

**A** Put the hook on the edge of the damper (Y) under the back edge of the fastening collar (K) of the fan (F) and push the damper down till the guiding edges of the valve go inside the rubber collar.

**B** Push the front edge of the collar with your finger.

**C** Put the hook on the front edge of the damper below the front edge of the collar.

When unfastening the damper, take the same steps in the opposite order.

Self-actuated one-way dampers are only used in VKL model units.

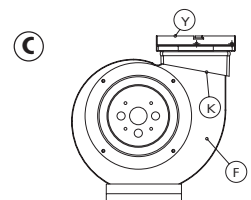
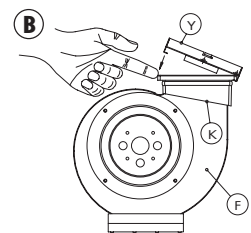
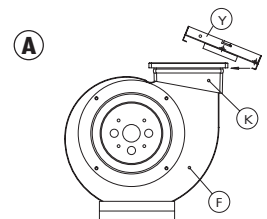



## MAINTENANCE INSTRUCTIONS

### Cooker hood (connected to the ventilation unit)

The most important object of maintenance is the grease filter. To ensure sufficient absorption capacity it needs to be cleaned sufficiently frequently, once or twice a month. The filter can usually be cleaned in a dishwasher for example. It is also important to keep the whole cooker hood clean. Neglecting the cleaning of the filter reduces the abatement of fumes and may cause a risk of fire. For more detailed maintenance instructions for instance on the changing of lamps, see the instructions of the cooker hood.

### Cooker hood (with an integrated fan)

Follow the same instructions as for the cooker hood connected to the ventilation unit. For special instructions, see the instructions of the cooker hood.

**NOTE! It is absolutely forbidden to flambé under the cooker hood.**



### Other parts of the ventilation system

#### Ductwork

In blocks of flats and terraced houses, the housing company takes care of the maintenance and cleaning of the ductwork in accordance with the regulations and instructions. In detached houses, the owner takes care of the cleaning.

#### Valves

The valves may be gently cleaned on the surface. It is forbidden to remove the valves and to change their adjustment values. Room dust may also gather around the supply air filter. The easiest way to remove it is to vacuum the valve with a brush nozzle. Dirt does not come from the ductwork with ventilation, but consists of dust in indoor air. This dust sticks to the ceiling or the wall caused by the flow coming from the valve.

#### VALVE OPERATION

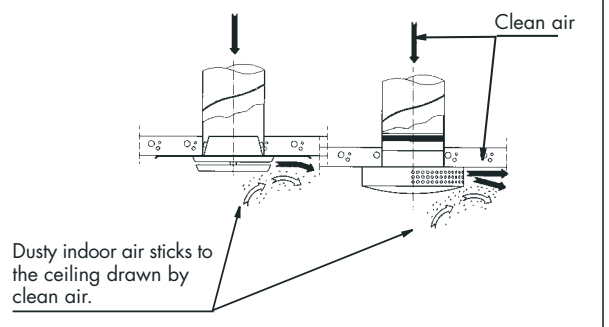



# VALLOX 75/95

## TROUBLESHOOTING

**In case of failure in a block of flats or terraced house, contact the person responsible for maintenance or a maintenance company.**

### 1. Outdoor air coming to the dwelling is cold.

- Air cools down in the attic ducts.
- The heat recovery cell is frozen, which is why extract air cannot heat outdoor air.
- The post-heating radiator does not work.
- The extract air filter or cell is clogged.
- The initial adjustment of ventilation has not been done.

#### DO THIS

- Measure the temperature of supply air in the unit and compare it with the air coming from the valve. If air cools down in the duct, check the insulation of the attic ducts.
- If the electric radiator does not heat up, check if the adjustment thermostat is in the desired position. (change the setting if needed) or if overheat protection has tripped (press the black button at the end of the radiator). If the protector has tripped, you hear a click when pressing the button. Pressing the button resets the radiator in working order after the tripping of the overheat protector. Consult an expert to find out why the overheat protector tripped. If the water radiator of the VKL model does not heat up, there might be many reasons for this: e.g. wrong position of thermostat; water does not circulate in the radiator; pump may be stopped or some of the valves off; water circulating in the radiator may be cold, etc. If necessary, consult an expert.
- If a filter or cell is clogged, clean it (see the instructions).
- If the initial adjustment has not been done, have it done.
- If the cell is frozen, check the operation of the defrost thermostat.

### 2. Other possible disturbances

- Outdoor air fan stops at too high outdoor temperatures.
- Both fans of the VKL model have stopped.

#### DO THIS

- If the fan keeps stopping at too high outdoor temperatures, check the operation of the defrost thermostat. The function starts as soon as outdoor temperature goes below  $-10^{\circ}\text{C}$ . The threshold is not absolute, but is dependent on the length of the ductworks, insulation, the speed of the unit and other things.
- If both fans of the VKL model have stopped, the defrost function of water-operated radiator is active.  
NOTE! If there is no non-freezing solution in the water of the radiator, the radiator is at risk of freezing and breaking down. If the radiator breaks down, there is a risk of water damage. Immediately troubleshoot the situation. Check if the circulation pump is broken, the boiler out of operation, etc. The situation may go return to normal by itself as soon as supply air temperature rises over  $10^{\circ}\text{C}$ , but do not wait till it happens.

#### You can influence the operation of the defrost thermostat as follows:

- If freezing occurs in the cell, you can put the sensor closer to the cell, which makes the fan stop earlier (the cell has to be thawed out before closing the lid).
- If the fan keeps stopping at too high outdoor temperatures (no humidity, no freezing), you can move the sensor further away from the cell.
- An expert may also adjust the thermostat in the connection box by turning its spindle clockwise to  $+10^{\circ}\text{C}$  or counter-clockwise to  $0^{\circ}\text{C}$ . At  $0^{\circ}\text{C}$  freezing is unlikely; at  $10^{\circ}\text{C}$  no freezing occurs but extract air can be too warm when going out. According to the factory setting, the defrost thermostat works at  $4^{\circ}\text{C}$ .



# VALLOX

Vallox Oy FIN-32200 Loimaa Finland Telephone +358 2 7636 300 Fax +358 2 7631 539  
www.vallox.com