

# Bruksanvisning Directions for use

HERU®62 T, HERU®90 T, HERU®90 T EC 2  
HERU®115 T, HERU®130 T EC, HERU®140 T  
HERU®50 S 2A, HERU®75 S 2A, HERU®90 S EC 2A  
HERU®130 S 2A, HERU®130 S EC 2A  
HERU®180 S 2A, HERU®180 S EC 2A



<b>AGGREGATBESKRIVNING</b> . . . . .	<b>3</b>
<b>INSTALLATION OCH SÄKERHET</b> . . . . .	<b>4</b>
"NYTTJANDE" "SÄKERHET" "GARANTI" "MONTAGE" . . . . .	4
"PLACERING" "FRITT UTRYMME" . . . . .	5
"PRINCIPSKISSER PLACERING" . . . . .	6
"MONTAGEANVISNINGAR" . . . . .	7-9
<b>UPPSTART</b> . . . . .	<b>10</b>
<b>REGLERSCHEMAN</b> . . . . .	<b>23-12</b>
<b>KOPPLINGSSCHEMAN</b> . . . . .	<b>13-22</b>
<b>REGLERFUNKTIONER</b> . . . . .	<b>23</b>
<b>MENYHANTERING</b> . . . . .	<b>24</b>
<b>VISNINGSLÄGEN 1-4</b> . . . . .	<b>25</b>
<b>HUVUDMENY</b> . . . . .	<b>26</b>
<b>MENY "FLÄKTHASTIGHET"</b> . . . . .	<b>26</b>
<b>MENY "TEMPERATUR"</b> . . . . .	<b>26</b>
<b>MENY "FORCERING"</b> . . . . .	<b>26</b>
<b>MENY "TRYCKKOMPENSERING"</b> . . . . .	<b>27</b>
<b>MENY "VECKOUR"</b> . . . . .	<b>27</b>
<b>MENY "HERU PÅ/AV"</b> . . . . .	<b>28</b>
<b>MENY "LARM"</b> . . . . .	<b>28</b>
<b>MENY "INSTÄLLNINGAR"</b> . . . . .	<b>29</b>
<b>MENY "SERVICEMENY"</b> . . . . .	<b>29-37</b>
"KONSTANT TRYCK" "TRYCKGIVARE" . . . . .	30
"FILTERMÄTNING" "EC-MOTOR SETUP" . . . . .	
"AC-MOTOR SETUP" . . . . .	31
"DISPLAY KONTRAST" "FORCERING" . . . . .	
"TRYCKKOMPENSERING" . . . . .	32
"LARM" "CO2" . . . . .	33
"RH" "EFTERVÄRMARE" "KYLVATTENBATTERI" . . . . .	34
"TILLUFTSGRÄNS" "REGLERTYP" "SOMMARKYLA" . . . . .	35
FRYSSKYDD "FLÖDESDIRIKTNING" . . . . .	
"LADDA/SPARA" "VERSION INFO" . . . . .	36
"MANÖVERENHET" . . . . .	37
<b>ÖVRIGA FUNKTIONER</b> . . . . .	<b>37</b>
<b>MÅTTSKISSER</b> . . . . .	<b>38-39</b>
<b>TEKNISKA DATA</b> . . . . .	<b>40</b>
<b>LJUDDATA</b> . . . . .	<b>41-51</b>
<b>TRYCK- OCH FLÖDESDIAGRAM</b> . . . . .	<b>52-56</b>
<b>SERVICE HERU T</b> . . . . .	<b>57</b>
<b>SERVICE HERU S</b> . . . . .	<b>58-59</b>
<b>SKIFTE AV ELEKTRISK EFTERVÄRMARE</b> . . . . .	<b>60</b>
<b>TILLBEHÖR</b> . . . . .	<b>61</b>
<b>RESERVDELSPÖRTECKNING</b> . . . . .	<b>62</b>
<b>FELSÖKNING</b> . . . . .	<b>63</b>
<b>FELSÖKNINGSSCHEMA</b> . . . . .	<b>64-65</b>
<b>EGNA INSTÄLLNINGAR</b> . . . . .	<b>66-67</b>
<b>EG-FÖRSÄKRAN</b> . . . . .	<b>68</b>

<b>UNIT DESCRIPTION</b> . . . . .	<b>71</b>
<b>INSTALLATION AND SECURITY</b> . . . . .	<b>72</b>
"USE" "SECURITY" "MOUNTING" "WARRANTY" . . . . .	72
"PLACING" "FREE SPACE" . . . . .	73
"SCHEMATIC DIAGRAMS FOR PLACING" . . . . .	74
"ASSEMBLY INSTRUCTIONS" . . . . .	75-77
<b>STARTING UP THE UNIT</b> . . . . .	<b>78</b>
<b>CONTROL DIAGRAMS</b> . . . . .	<b>79-80</b>
<b>WIRING DIAGRAMS</b> . . . . .	<b>81-90</b>
<b>REGULATION FUNCTIONS</b> . . . . .	<b>91</b>
<b>OPERATING THE CONTROL UNIT</b> . . . . .	<b>92</b>
<b>VIEW MODES 1-4</b> . . . . .	<b>93</b>
<b>MAIN MENU</b> . . . . .	<b>94</b>
<b>"FAN SPEED" MENU</b> . . . . .	<b>94</b>
<b>"TEMPERATURE" MENU</b> . . . . .	<b>94</b>
<b>"BOOST" MENU</b> . . . . .	<b>94</b>
<b>"OVERPRESSURE" MENU</b> . . . . .	<b>95</b>
<b>"WEEK TIMER" MENU</b> . . . . .	<b>95</b>
<b>"UNIT ON/OFF" MENU</b> . . . . .	<b>96</b>
<b>"ALARMS" MENU</b> . . . . .	<b>96</b>
<b>"SETTINGS" MENU</b> . . . . .	<b>97</b>
<b>THE "SERVICE MENU"</b> . . . . .	<b>97-33</b>
"CONSTANT PRESSURE" "PRESSURE INPUTS" . . . . .	98
"FILTER MEASUREMENT" "EC FAN SETUP" . . . . .	
"AC FAN SETUP" . . . . .	99
"DISPLAY CONTRAST" "BOOST" "OVERPRESSURE" . . . . .	100
"ALARM" "CO2" . . . . .	101
"RH" "HEATER" "COOLER" . . . . .	102
"SUPPLY LIMITS" "REGULATION MODE" . . . . .	
"SUMMER COOLING" . . . . .	103
"FREEZE PROTECTION" "FLOW DIRECTION" . . . . .	
"LOAD/SAVE SETTINGS" "VERSION INFO" . . . . .	104
"DEVICE PAIRS" . . . . .	105
<b>OTHER FUNCTIONS</b> . . . . .	<b>105</b>
<b>DIMENSIONS</b> . . . . .	<b>106-107</b>
<b>TECHNICAL DATA</b> . . . . .	<b>108</b>
<b>SOUND DATA</b> . . . . .	<b>109-119</b>
<b>PRESSURE/FLOW DIAGRAMS</b> . . . . .	<b>120-124</b>
<b>SERVICE HERU T</b> . . . . .	<b>125</b>
<b>SERVICE HERU S</b> . . . . .	<b>126-127</b>
<b>CHANGE PLACE OF THE HEATER</b> . . . . .	<b>128</b>
<b>ACCESSORIES</b> . . . . .	<b>129</b>
<b>SPARE PARTS</b> . . . . .	<b>130</b>
<b>ERROR DETECTION</b> . . . . .	<b>131</b>
<b>ERROR DETECTION DIAGRAM</b> . . . . .	<b>132-133</b>
<b>INTERNAL SETTINGS</b> . . . . .	<b>134-135</b>
<b>EC DECLARATION</b> . . . . .	<b>69</b>

This "Direction for use" contains following products:  
 HERU®62 T, HERU®90 T, HERU®90 T EC 2, HERU®115 T,  
 HERU®130 T EC, HERU®140 T,  
 HERU®50 S 2A, HERU®75 S 2A, HERU®90 S EC 2A, HERU®130 S 2A,  
 HERU®130 S EC 2A, HERU®180 S 2A and HERU®180 S EC 2A



## UNIT DESCRIPTION

- There are two models of the energy recovery unit HERU®, T and S with AC or EC motors. They are designed for supply and exhaust air ventilation combined with heat and cool recovery.
- HERU® can be used in homes, offices, apartments etc. where there is a need for:
  - high temperature efficiency
  - energy saving
  - low sound levels
  - safe operation
- HERU® has;
  - a rotating heat exchanger, of non-hygroscopic type and is manufactured of aluminium, placed centrally in the unit. The heat exchanger has a temperature efficiency of up to 86%.
  - forward- or backwardcurved centrifugal fans with maintenance free external rotor motors, which are connected with quick contacts, and are easily to remove for cleaning.
  - a built-in electric heater with pulser.
  - as standard, disposable rigid filter F7 (HERU®T) and bagfilter F7 (HERU®S).
  - a wireless remote controller for the operation and monitoring of the unit.
  - a double skinned galvanised sheet steel casing with 17 mm insulation (HERU®T) respective 50 mm intermediate insulation (HERU®S).
- The HERU®T is mounted in a warm space as e.g. the utility room. The HERU®S can be mounted in either warm or cold space.
- The HERU®T is delivered in white as standard and the HERU®S is galvanised.
- HERU®EC is operated via a wireless remote controller which can operate and to preset the required parameters as well as monitor the unit's status. The operating range is approximately 50 meters. The antenna which is placed next to the unit can have the range reduced if there are heavy reinforcing bars in the concrete structure and it should then be moved either to a position where the signal is not shielded or nearer to the controller.
- All HERU® units are equipped with a wall plug except for HERU®180 S which has an access cable.
- HERU®90 T EC 2 has an integrated silencer.

## INSTALLATION AND SECURITY

### USE

- When installing HERU® consideration must be given to any approval authority requirements and recommendations concerning siting, accessibility, electrical connections, etc.
- The HERU® unit is accessible for the user, according to IEC 60335-2-40, to by themselves do the service and maintenance, according to this Directions for use. But before this work the unit must be currentless.  
With reservation according to IEC 60335-2-7.12 "This appliance is not intended for use by persons (including children) with reduced physical, sensory or mental capabilities, or lack of experience and knowledge, unless they have been given supervision or instruction concerning use of the appliance by a person responsible for their safety."  
"Children should be supervised to ensure that they do not play with the appliance."
- The HERU® unit should be storage in a sheltered and dry place before installation.
- Dimensioned air flow should not exceed 60% of the unit's maximum capacity.
- Check at regular intervals that supply air and exhaust air works.
- **To avoid condensation in the unit during the cold season, the unit should not be turned off for a longer period.** When installed in warm moisture environment as e.g. bathroom and utilityroom condense may appear on the outside of the unit at low outside temperatures.

### SECURITY

- Attention, look out for sharp edges and corners on the HERU® unit and fans.
- Consider the weight of the unit. See page 108.
- Before maintenance work the HERU® unit must be currentless. If there is a need of changing or complement any electrical components, it should be done by a qualified person.
- The HERU® unit includes rotating parts that could cause serious danger on the occasion of contact. This is why the unit must be duct connected and the lid closed with the screws tightened, before starting up the unit.
- After the current is cut for service and maintenance the electric heater may still be warm.
- Make sure that the access cable is not damage at mounting and installation.
- HERU® must be equipped with earth fault breaker.
- The HERU®180 S needs a permanent electrical supply. The unit must be connected via a safety switch. Any electrical connections must be made by a qualified electrician.

### MOUNTING THE HERU®T

- The HERU®T should be installed according to the assembly instruction on pages 75-76.
- The unit should be fixed on the wall with fasteners gear to the construction of the wall.
- Avoid mounting on a wall adjacent to bedroom.
- The unit should be mounted on an insulated wall.

- Use duct clamp or flange with encompassing insulation when connecting to duct.
- If the supply and the exhaust air ducts are installed in a cold space they should be insulated. To prevent condensation the supply air duct should also be insulated if installed in warm space at low supply air temperatures.
- The fresh air and extract air duct should always be condense insulated.
- The ducts should be insulated all the way towards the unit.
- The duct sensor GT7 is mount in the supply air duct, and the antenna on a suitably position beside the unit (not against metal).
- Acoustic silencer should be planned with the help of sound data and required sound levels.
- If a heating coil is connected a cut off damper must be mounted in the fresh air duct.
- Cooker hood (available as an assessor) can be connected to HERU®62 T, 90 T, 115 T, 130 T EC and 140 T where the exhaust air is not passing through filter or the heat exchanger.
- Consider that kitchen ducts in houses must be mounted with the lowest fire resistance class E15 and with a safety distance of minimum 30 mm to combustible material. The kitchen duct must also be equipped with a cleaning door.

### MOUNTING THE HERU®S

- HERU®S should be installed according to the assembly instruction on page 77.
- Place the unit on a ground board, min. 50 mm.
- Supply and exhaust air must be duct connected on the same side of the unit.
- Acoustic silencer should be planned with the help of sound data and required sound levels.
- Use duct clamp or flange with encompassing insulation when connecting to duct.
- If the supply and the exhaust air ducts are installed in a cold space they should be insulated. To prevent condensation the supply air duct should also be insulated if installed in warm space at low supply air temperatures.
- The fresh air and extract air duct should always be condense insulated.
- The ducts should be insulated all the way towards the unit.
- The duct sensor GT7 is mount in the supply air duct, and the antenna on a suitably position beside the unit (not against metal).
- If a heating coil is connected a cut off damper must be mounted in the fresh air duct.
- Cooker hoods must not be connected to the HERU®S because of the increased cleaning demand.
- Ducting must be connected to external ground on the unit, see picture.

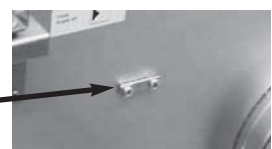

### WARRANTY

The warranty is only valid under condition that the HERU® unit is used according to this "Directions for Use" and a regular maintenance has been record.

**PLACING THE HERU®T UNIT**

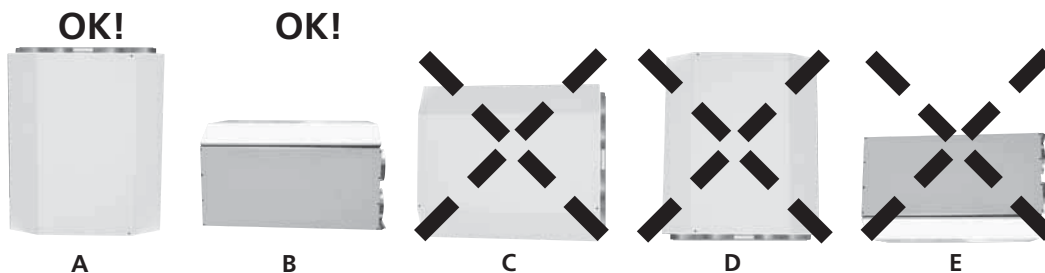

The HERU®T should be installed with the duct connections upwards (A) but can also be placed decumbently (B). We do not recommend installing the unit on one side (C), with the duct connections (D) or lid downwards (E). Allowances must be made to access the unit for servicing or maintenance.

**PLACING THE HERU®S UNIT**

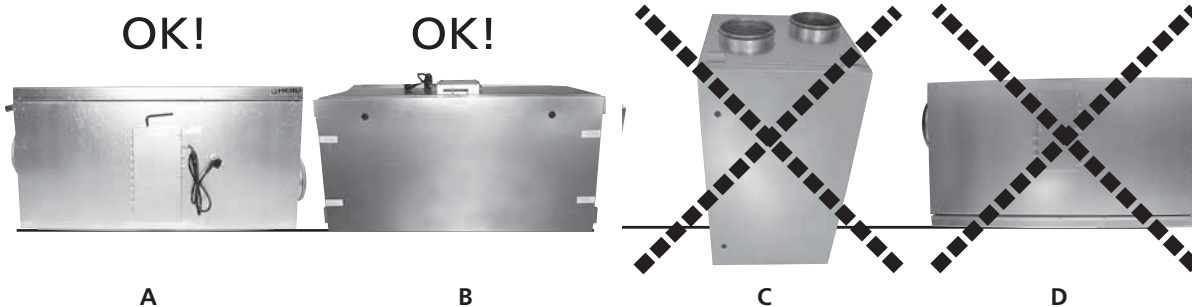

The HERU®S should be installed with the lid upwards (A) or on the side (B), we do not recommend installing the unit vertically (C) or with the lid downwards (D). Allowances must be made to access the unit for servicing or maintenance.

**FREE SPACE FOR SERVICE AND MAINTENANCE**

**HERU®62 T, 90 T, 90 T EC 2**  
Max aperture angle 90°.

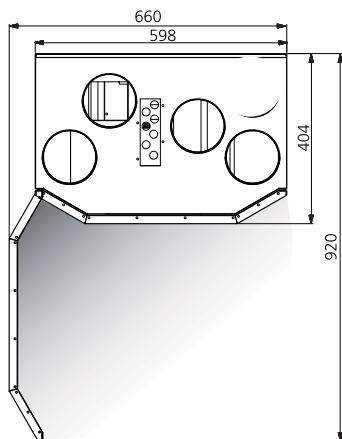

**HERU®S**

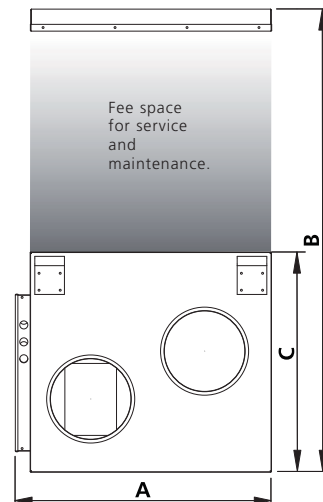

**HERU®115 T, 130 T EC, 140 T**  
Max aperture angle 130°.

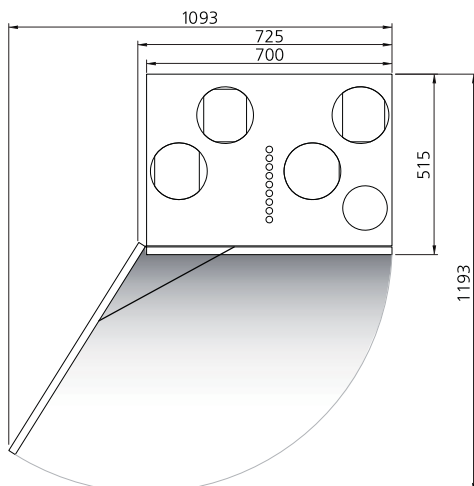

mm	A	B	C
HERU®50 S 2A, 75 S 2A, 90 S EC 2A	555	800	420
HERU®130 S 2A, 130 S EC 2A	605	1000	521
HERU®180 S 2A, 180 S EC 2A	715	1220	631

**SCHEMATIC DIAGRAM FOR HERU®T EC PLACED IN A WARM SPACE**

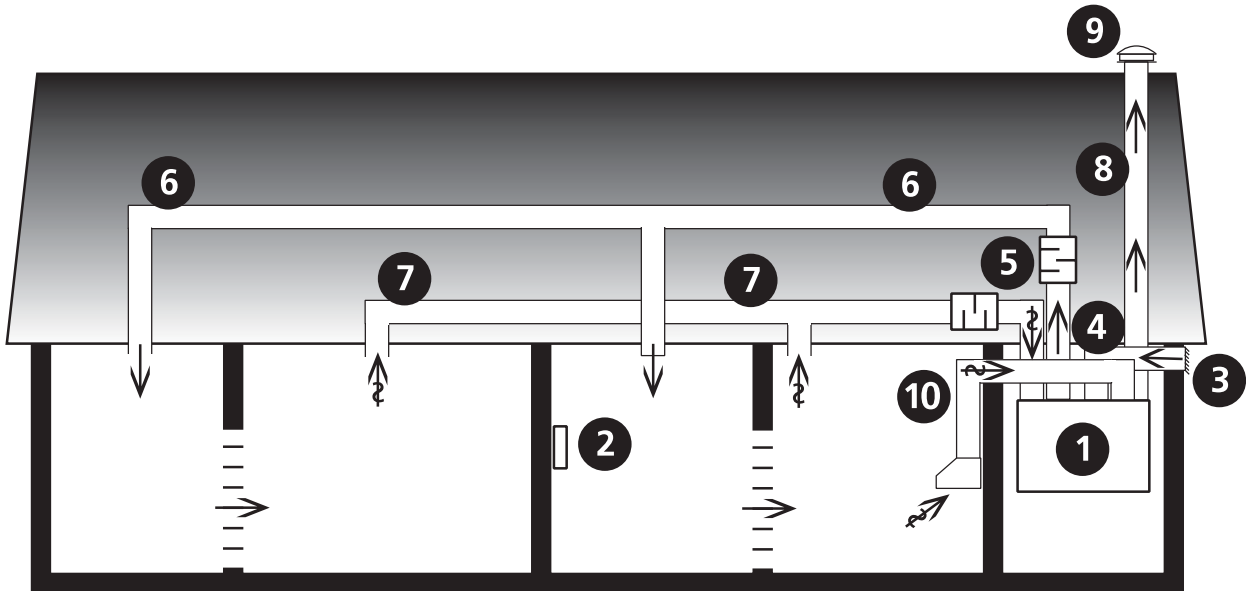

- |                           |                    |                    |
|---------------------------|--------------------|--------------------|
| 1 Heat recovery unit HERU | 5 Silencer         | 8 Extract air duct |
| 2 Control unit            | 6 Supply air duct  | 9 Roof terminal    |
| 3 Intake grille           | 7 Exhaust air duct | 10 Cooker hood     |
| 4 Fresh air duct          |                    |                    |

**SCHEMATIC DIAGRAM FOR HERU®S PLACED IN AN ATIC**

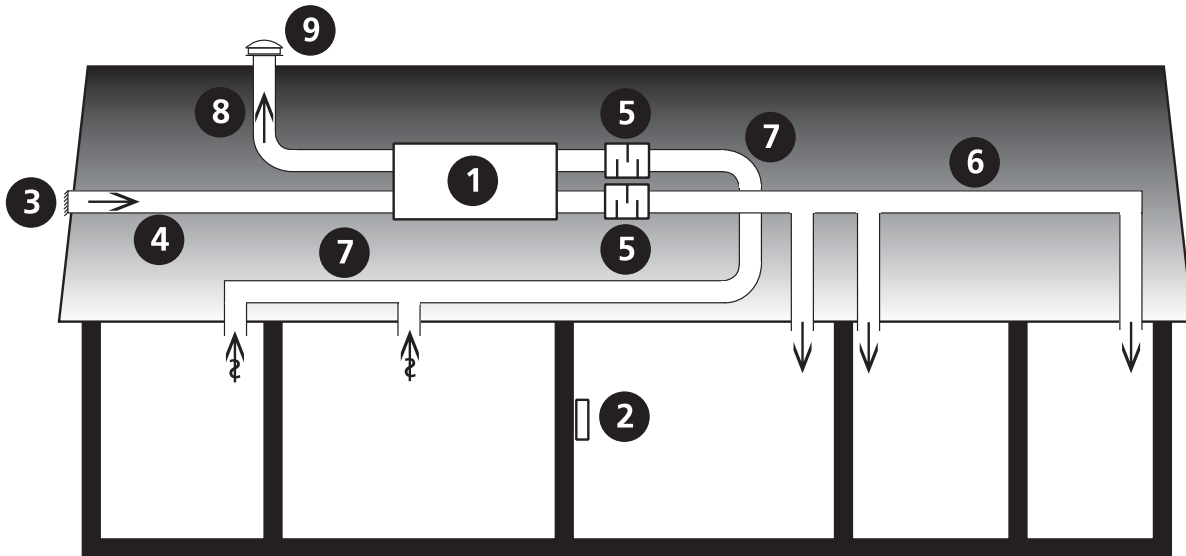

- |                           |                   |                    |
|---------------------------|-------------------|--------------------|
| 1 Heat recovery unit HERU | 4 Fresh air duct  | 7 Extract air duct |
| 2 Control unit            | 5 Silencer        | 8 Exhaust air duct |
| 3 Intake grille           | 6 Supply air duct | 9 Roof terminal    |

## ASSEMBLY INSTRUCTION FOR HERU®90 T EC 2

Mount the unit with concomitant rubber cushions and adequate screws for the foundation.  
NB! The concomitant rubber cushions can be compressed to a thickness of maximum 10 mm.  
The unit is not supplied with wall screws.

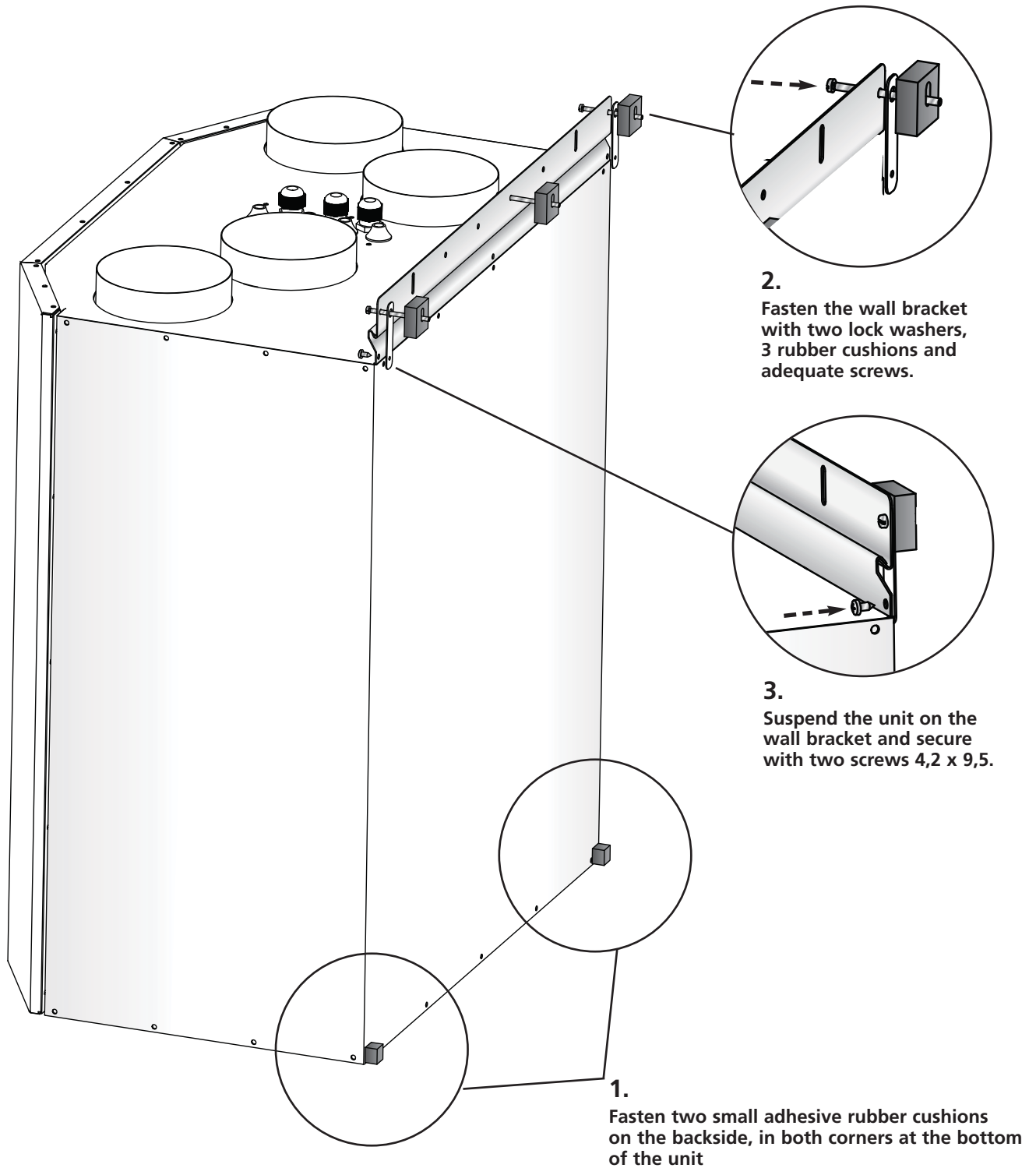

## ASSEMBLY INSTRUCTION FOR HERU®130 T EC

Mount the unit with concomitant rubber cushions and adequate screws for the foundation.  
 NB! The concomitant rubber cushions can be compressed to a thickness of maximum 10 mm.  
 The unit is not supplied with wall screws.

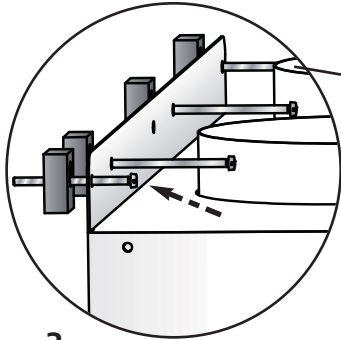

- 3.**  
 Place the unit on to the wall bracket and fasten with 4 rubber cushions and adequate screws.

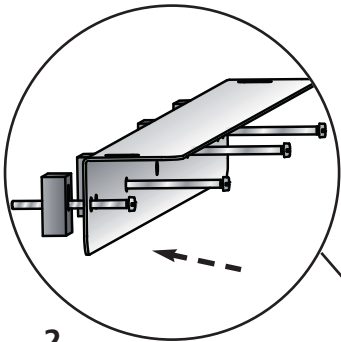

- 2.**  
 Turn the wall bracket 180° and fasten on to the wall with 4 rubber cushions and adequate screws.

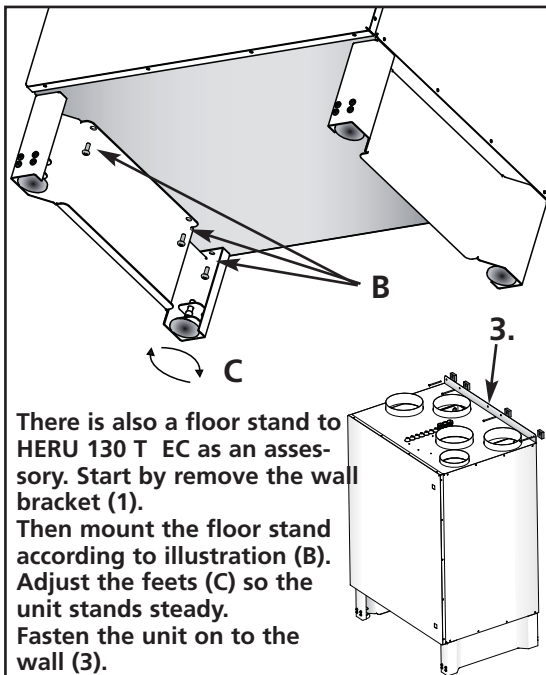

There is also a floor stand to HERU 130 T EC as an accessory. Start by remove the wall bracket (1). Then mount the floor stand according to illustration (B). Adjust the feet (C) so the unit stands steady. Fasten the unit on to the wall (3).

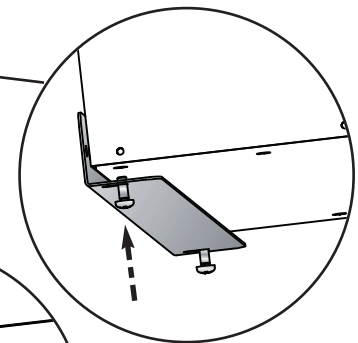

- 1.**  
 Unscrew the wall bracket.

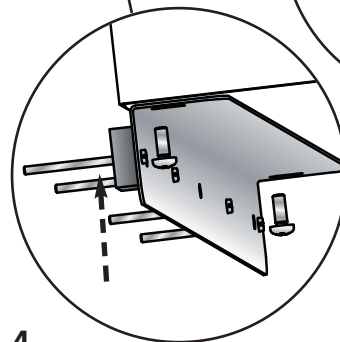

- 4.**  
 Fasten the unit on to the wall bracket with the two removed screws.



**ASSEMBLY INSTRUCTION FOR HERU®S**

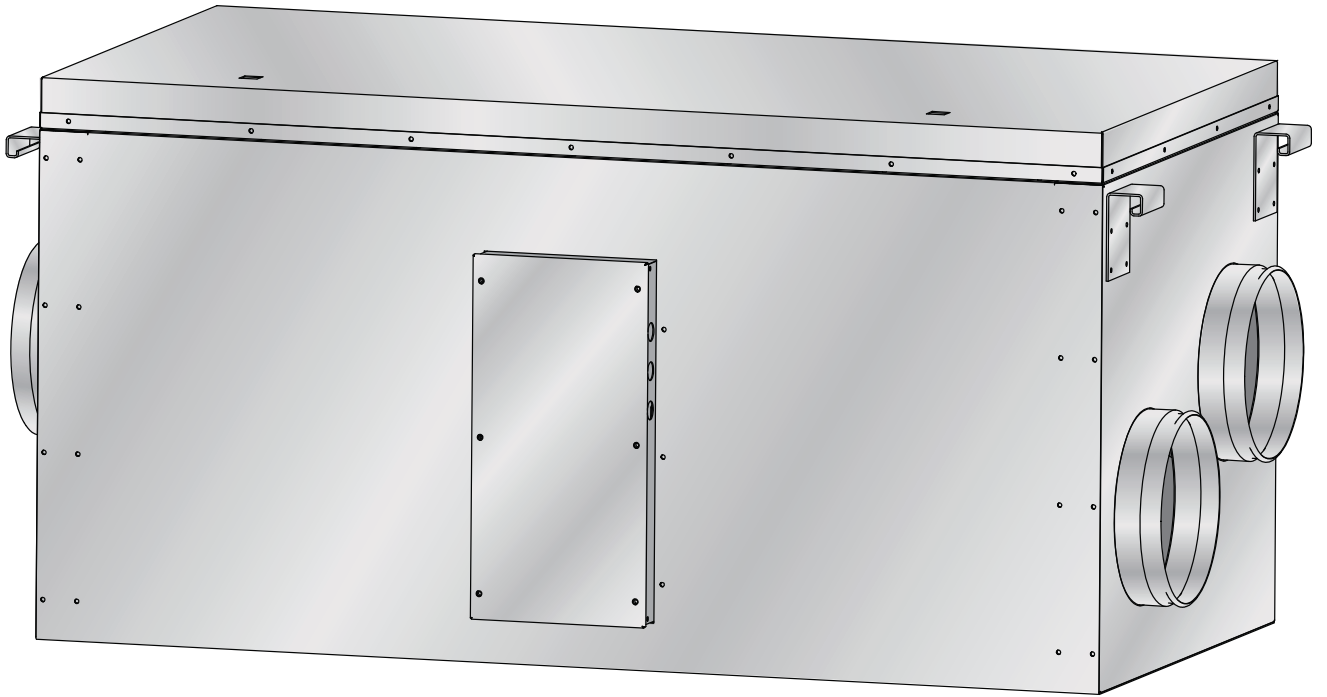

**INSULATING  
BOARD  
min.  
50 mm**

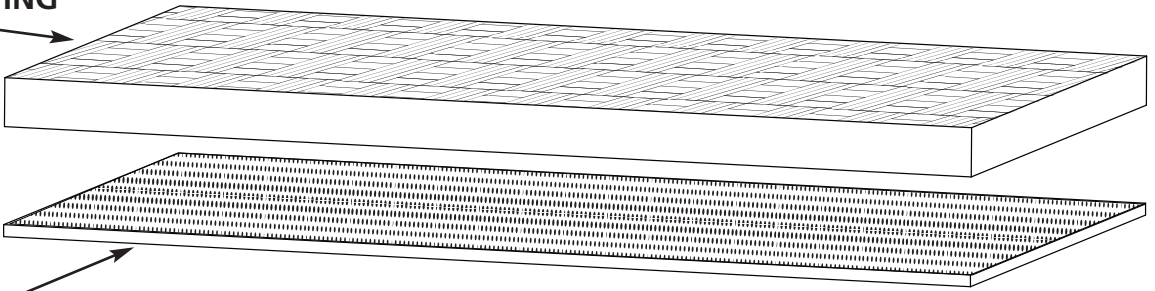

**E.G. PLYWOOD TIGHTENED TO JOISTS**

## STARTING UP THE UNIT **NB!** Important information before starting!

Carefully read through the manual before starting up the unit.

- **NB!** Always mount the temperature sensor GT7 in the supply air duct. See page 79-80. GT7 is connected at the relay card. The temperature sensor GT7 for HERU®S EC is in the connection box when delivered. For HERU®90 T EC2 the GT7 is mounted in the unit.

- The antenna should be mounted outside the unit. The antenna for HERU® is delivered connected, and for HERU®S it is in the connection box.

**NB!** The antenna should not be mounted against any metal area or metal items as this will shield the signal.

The antenna should be mounted as central as possible. This to achieve the best signal all over the house. If neede an extension cord is available as an accessorie.

- Install the 3 AA batteries in the wireless control unit that are placed inside the HERU® when delivered.

- HERU®EC starts automatically (with a few minutes delay) when the current is switched on, or alternative with the wireless control unit. At power outage, always check so the unit is starting up again.

- HERU®S is supplied for right handing application, see picture below. If the unit is installed left handed then changes can be made in the "Service Menu" and in the submenu "Flow Direction".

See page 104.

**NB!** If left handing application, the electrical heater must be moved. See page 128.

- **Important when adjusting the flow:** Go to Service Menu (password 1199), choose "AC -motor setup" or "EC-motor setup". This disable functions such as Summer cooling or Boost during flow adjustment. The fan speed is standard. See page 100.

When adjusting the airflow of AC-fans there is a possibility to change the voltage for the different fan speeds via the separate transformers-rerna for supply resp. exhaust fan. Normal operation should be done in standard mode. HERU®50/75 S has 5-step transformers and HERU®130/180 S has 7-step. See wiring diagrams on pages 81, 83, 85, 87 and 89.

**NB!** When adjusting fan speed manually, make sure that the speed keeps the sequences.

- All HERU® has an electric heater as standard. Choose heater "On/Off" according to the instruction on page 102. För external Heater see instruction on page 102.

- Set the temperature according to the instruction on page 94.

- Save settings according to the instruction on page 104.

- **NB!** The unit must not be operating without filter.



HERU®90 T EC 2

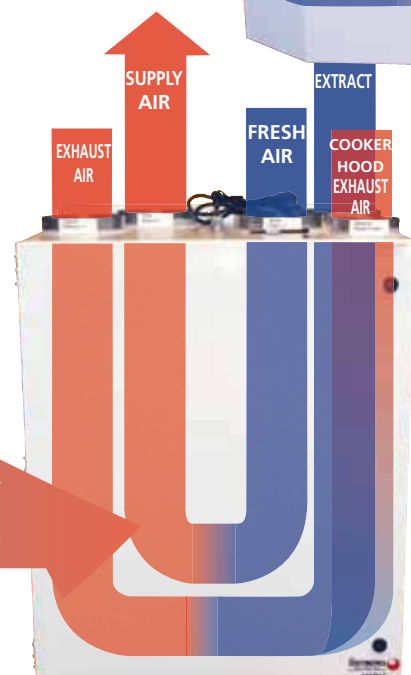

HERU®130 T EC

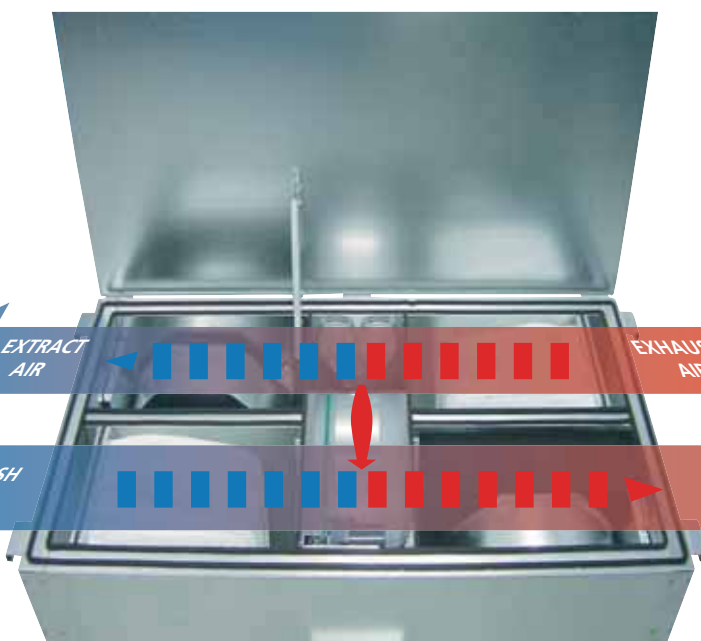

HERU®S

# CONTROL DIAGRAM HERU® T shows all sensors

HERU®90 T EC 2:

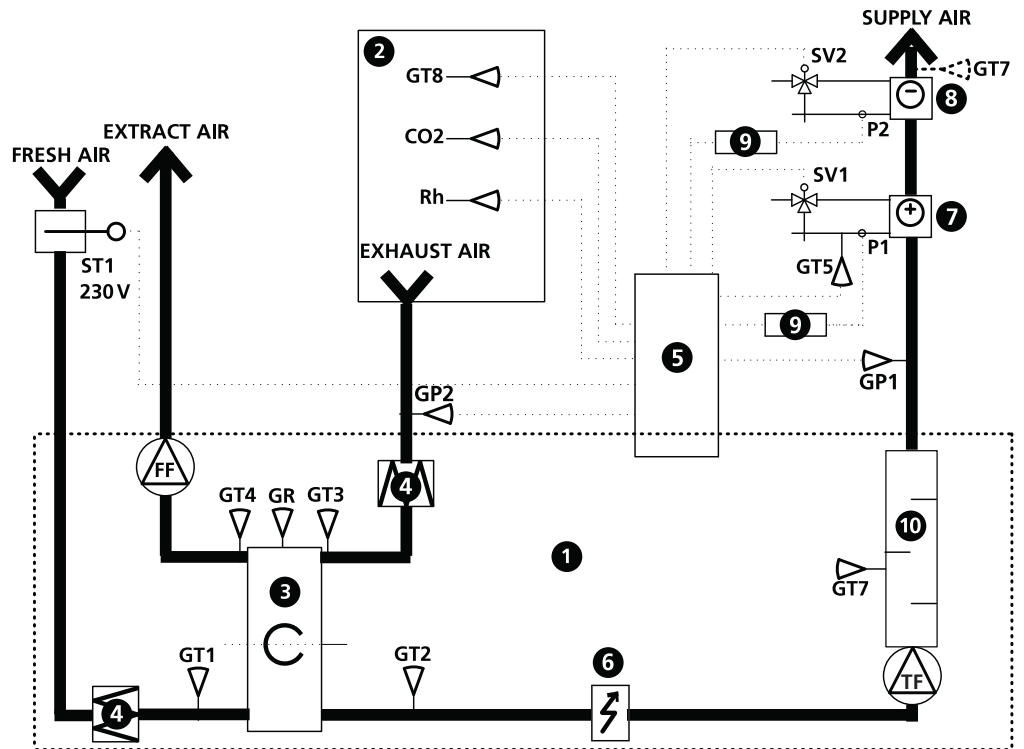

- |                           |  |                                 |
|---------------------------|--|---------------------------------|
| 1 Heat recovery unit HERU | ST1 Damper motor with pull back spring           | GP1 Pressure sensor supply air  |
| 2 Room                    | GR Rotor sensor                                  | GP2 Pressure sensor exhaust air |
| 3 Rotary heat exchanger   | GT1 Internal temp. sensor fresh air              | Rh Room sensor, humidity        |
| 4 Filter                  | GT2 Internal temp. sensor supply air             | CO2 Room sensor, carbon dioxide |
| 5 Electric control board  | GT3 Internal temp. sensor exhaust air            | SV1 Valve, heating              |
| 6 Electrical heater       | GT4 Internal temp. sensor extract air            | SV2 Valve, cooling              |
| 7 Heating coil            | GT5 Freeze protection sensor                     | TF Supply air fan               |
| 8 Cooling coil            | GT7 Temperature duct sensor supply air (min/max) | FF Exhaust air fan              |
| 9 Relay                   | GT8 Temperature duct sensor room                 | P1 Circulation pump, cold water |
| 10 Silencer               |  | P2 Circulation pump, hot water  |

HERU®62 T,  
HERU®90 T,  
HERU®115 T,  
HERU®130 T EC,  
HERU®140 T:

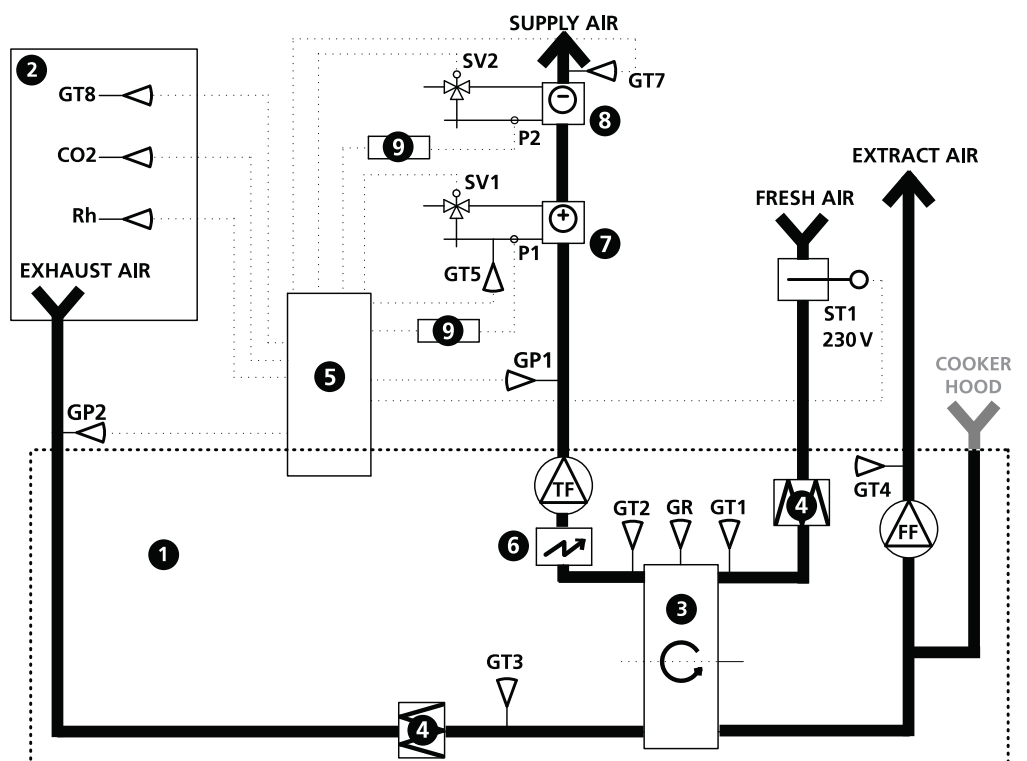

## CONTROL DIAGRAM HERU<sup>®</sup>S shows all sensors

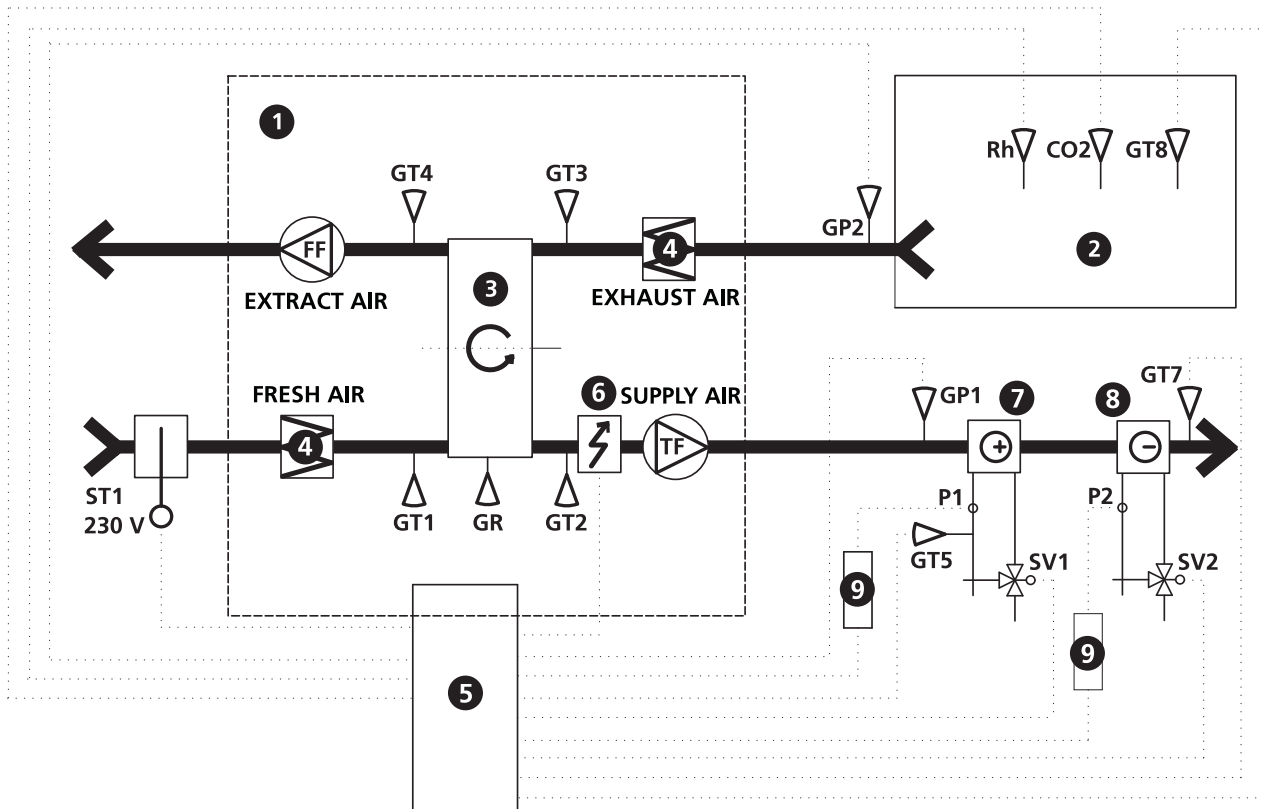

- |                           |  |                                 |
|---------------------------|--|---------------------------------|
| 1 Heat recovery unit HERU | ST1 Damper motor with pull back spring           | GT8 Temperature duct sensor     |
| 2 Room                    | GP1 Pressure sensor supply air                   | Rh Room sensor, humidity        |
| 3 Rotary heat exchanger   | GP2 Pressure sensor exhaust air                  | CO2 Room sensor, carbon dioxide |
| 4 Filter                  | GR Rotor sensor                                  | SV1 Valve, heating              |
| 5 Electric control board  | GT1 Internal temp. sensor fresh air              | SV2 Valve, cooling              |
| 6 Electrical heater       | GT2 Internal temp. sensor supply air             | TF Supply air fan               |
| 7 Heating coil            | GT3 Internal temp. sensor exhaust air            | FF Exhaust air fan              |
| 8 Cooling coil            | GT4 Internal temp. sensor extract air            | P1 Circulation pump, hot water  |
| 9 Relay                   | GT5 Freeze protection sensor                     | P2 Circulation pump, cold water |
|                           | GT7 Temperature duct sensor supply air (min/max) |                                 |

## WIRING DIAGRAM for electrical duct heater

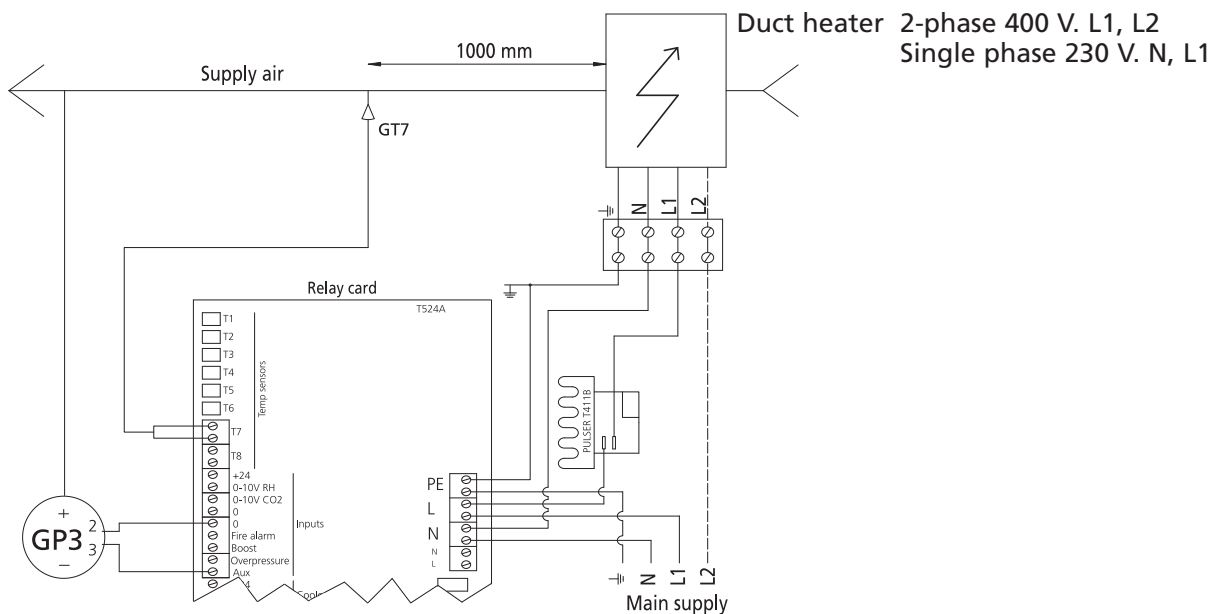

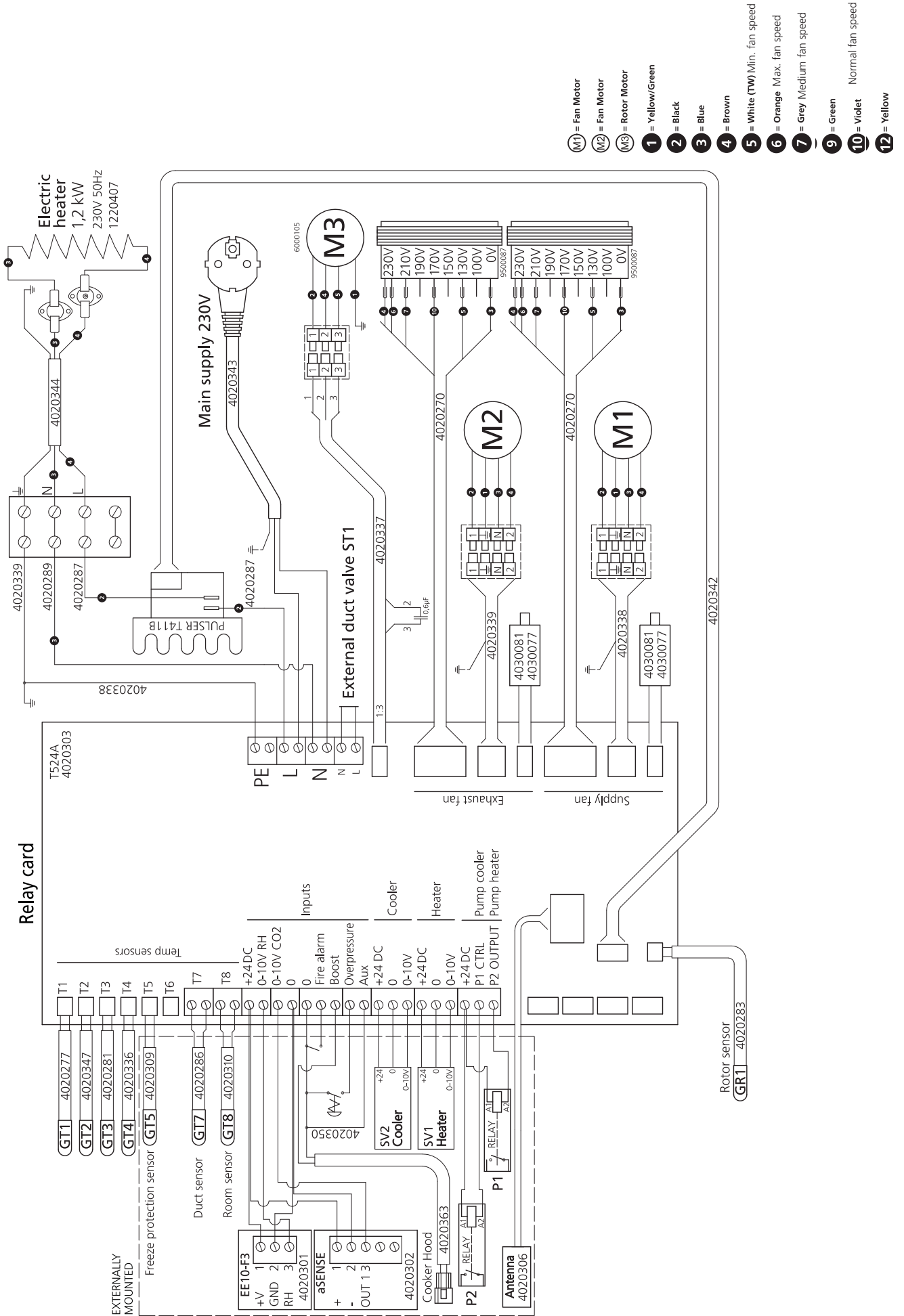

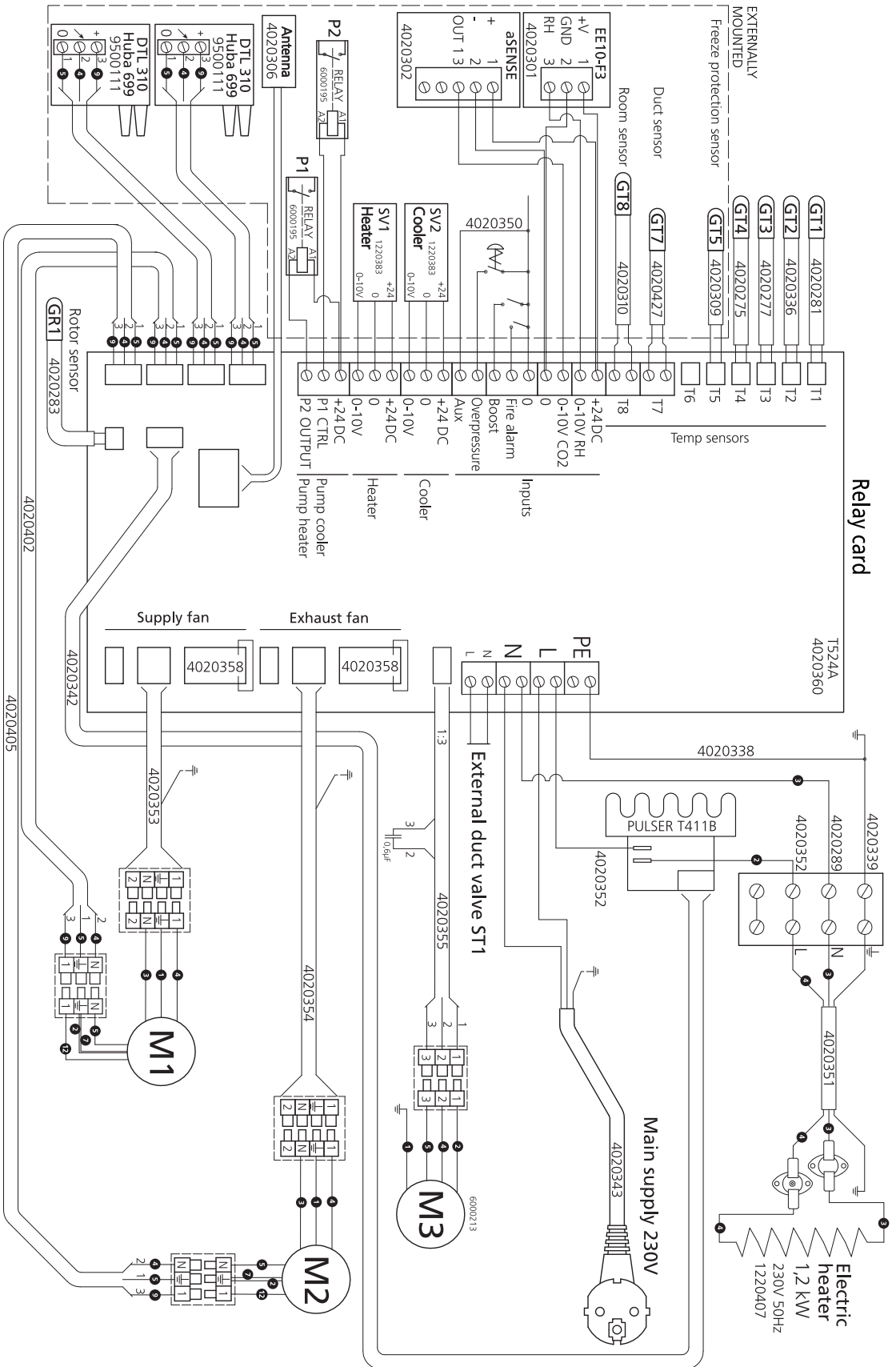

- ⊙ M1 = Fan Motor
- ⊙ M2 = Fan Motor
- ⊙ M3 = Rotor Motor
- ① = Yellow/Green
- ② = Black
- ③ = Blue
- ④ = Brown
- ⑤ = White (TW)
- ⑥ = Orange
- ⑦ = Grey
- ⑨ = Green
- ⑩ = Violet
- ⑫ = Yellow

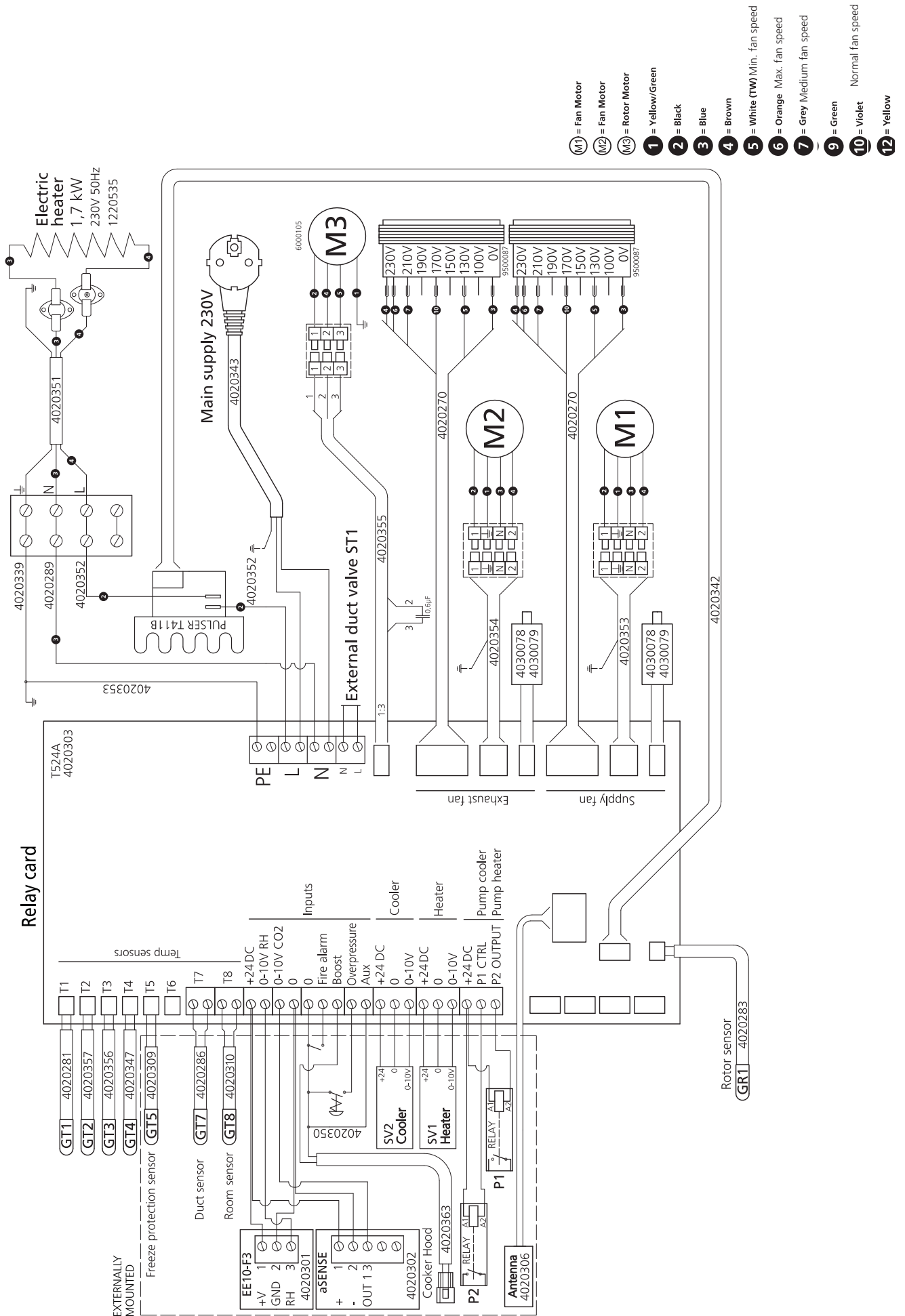

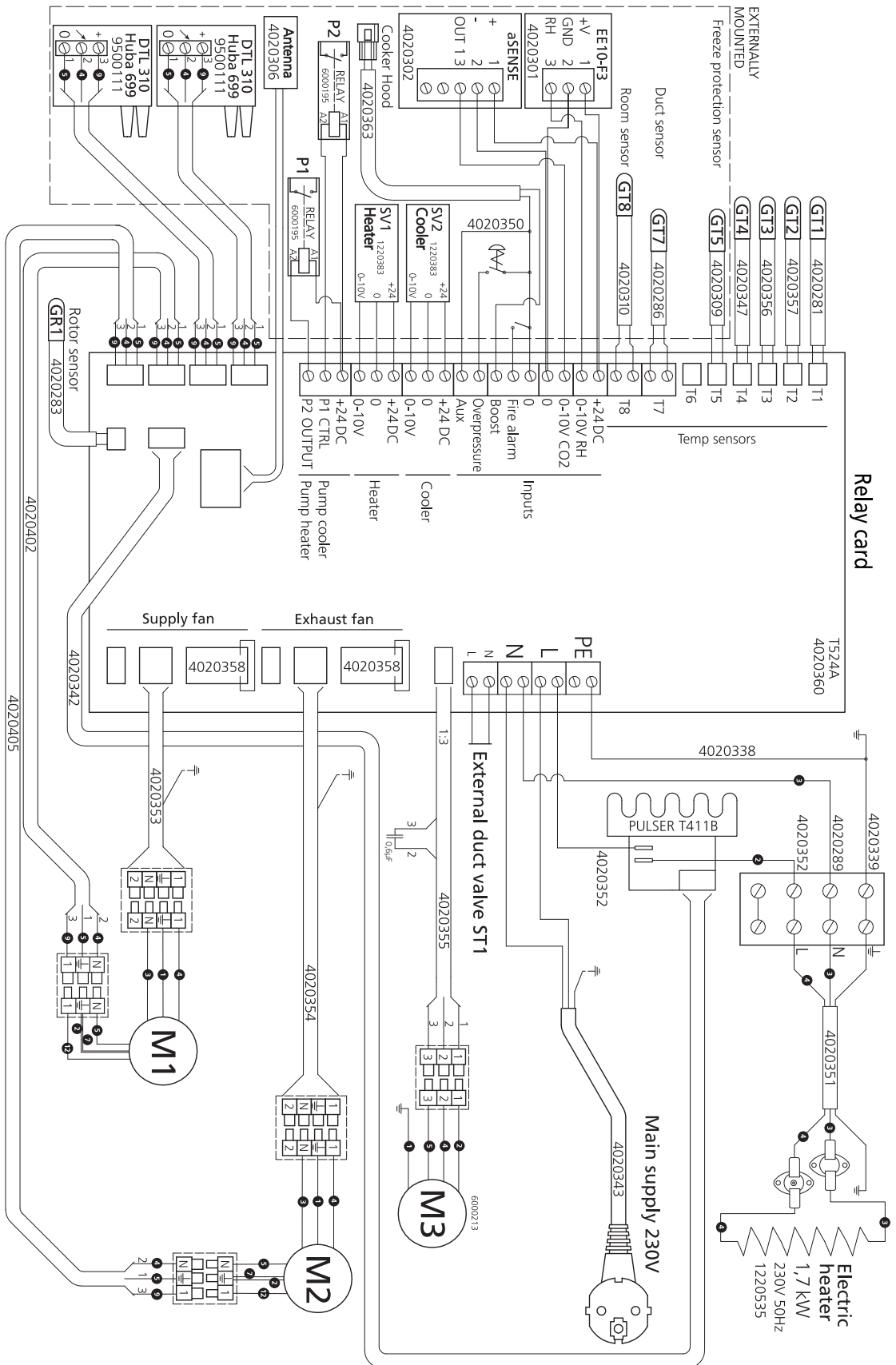

- (M1) = Fan Motor
- (M2) = Fan Motor
- (M3) = Rotor Motor
- 1 = Yellow/Green
- 2 = Black
- 3 = Blue
- 4 = Brown
- 5 = White (TW)
- 6 = Orange
- 7 = Grey
- 9 = Green
- 10 = Violet
- 12 = Yellow



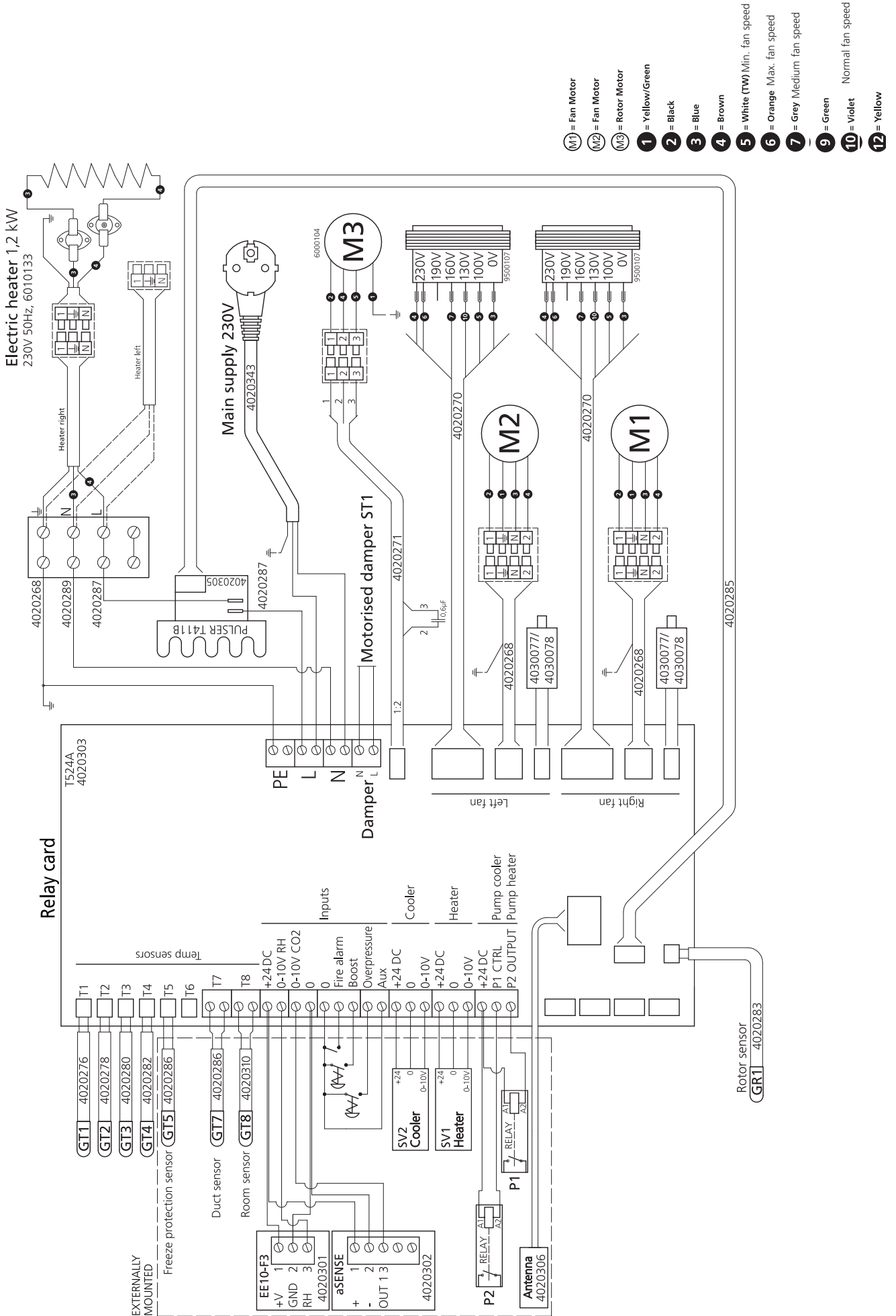

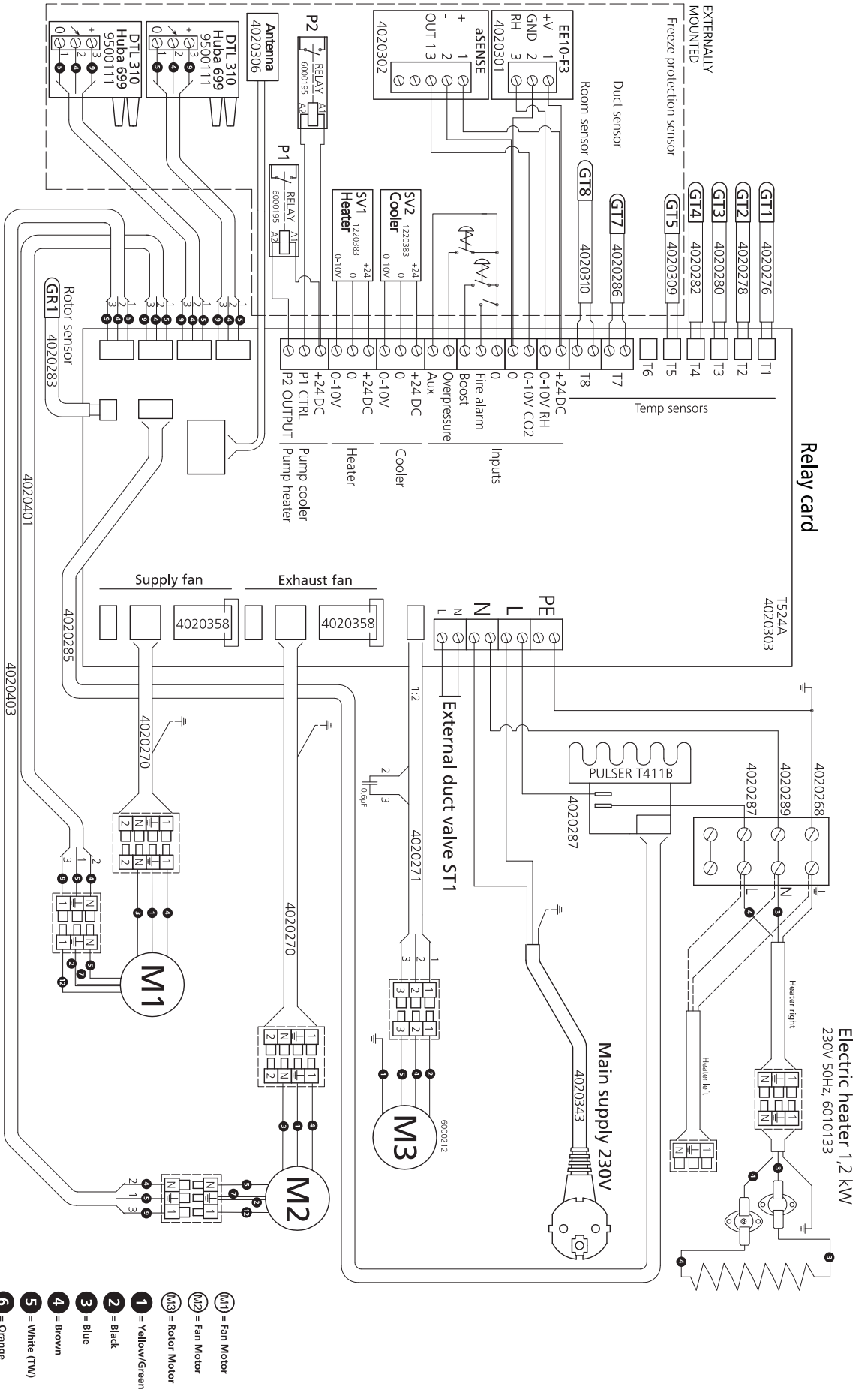

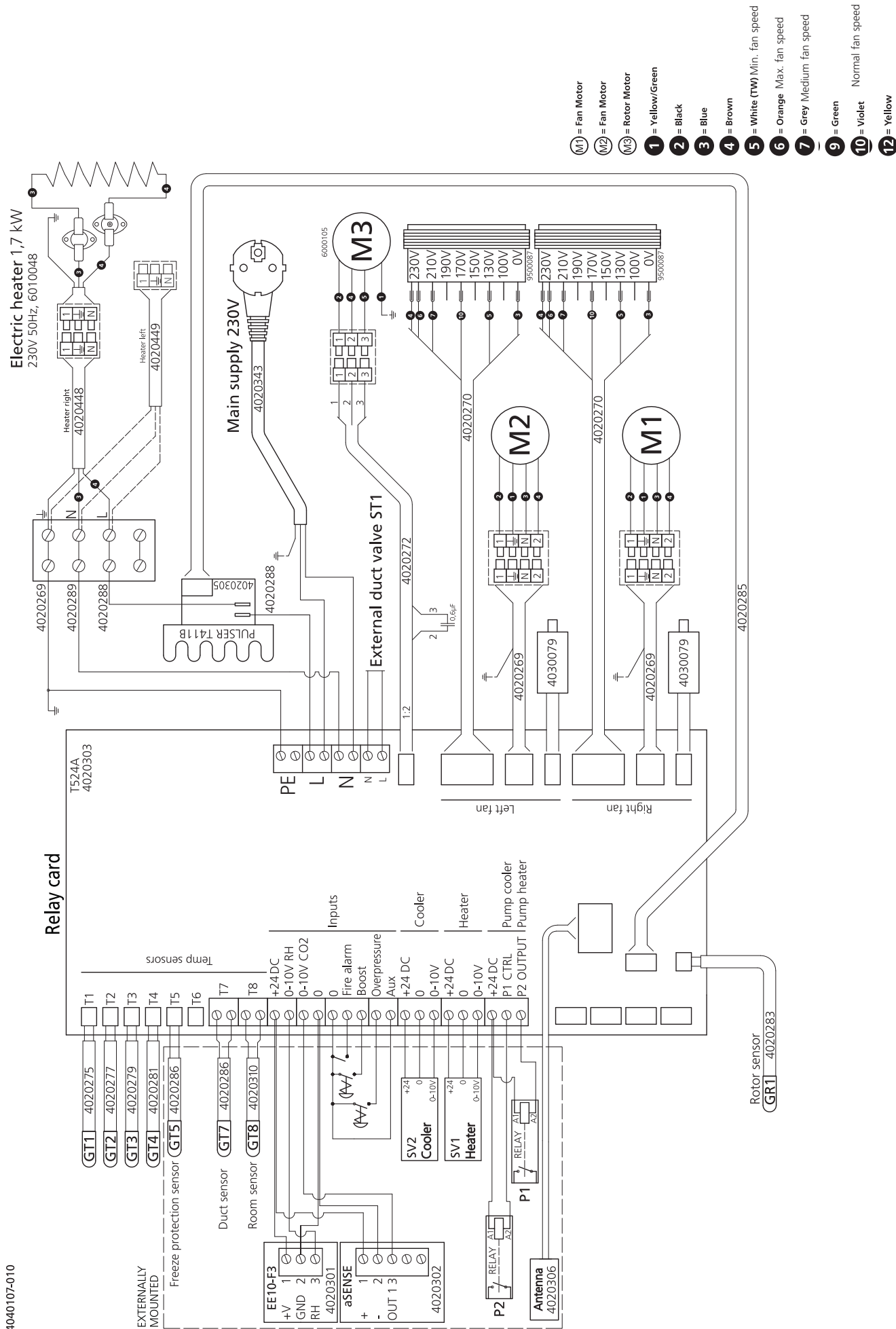

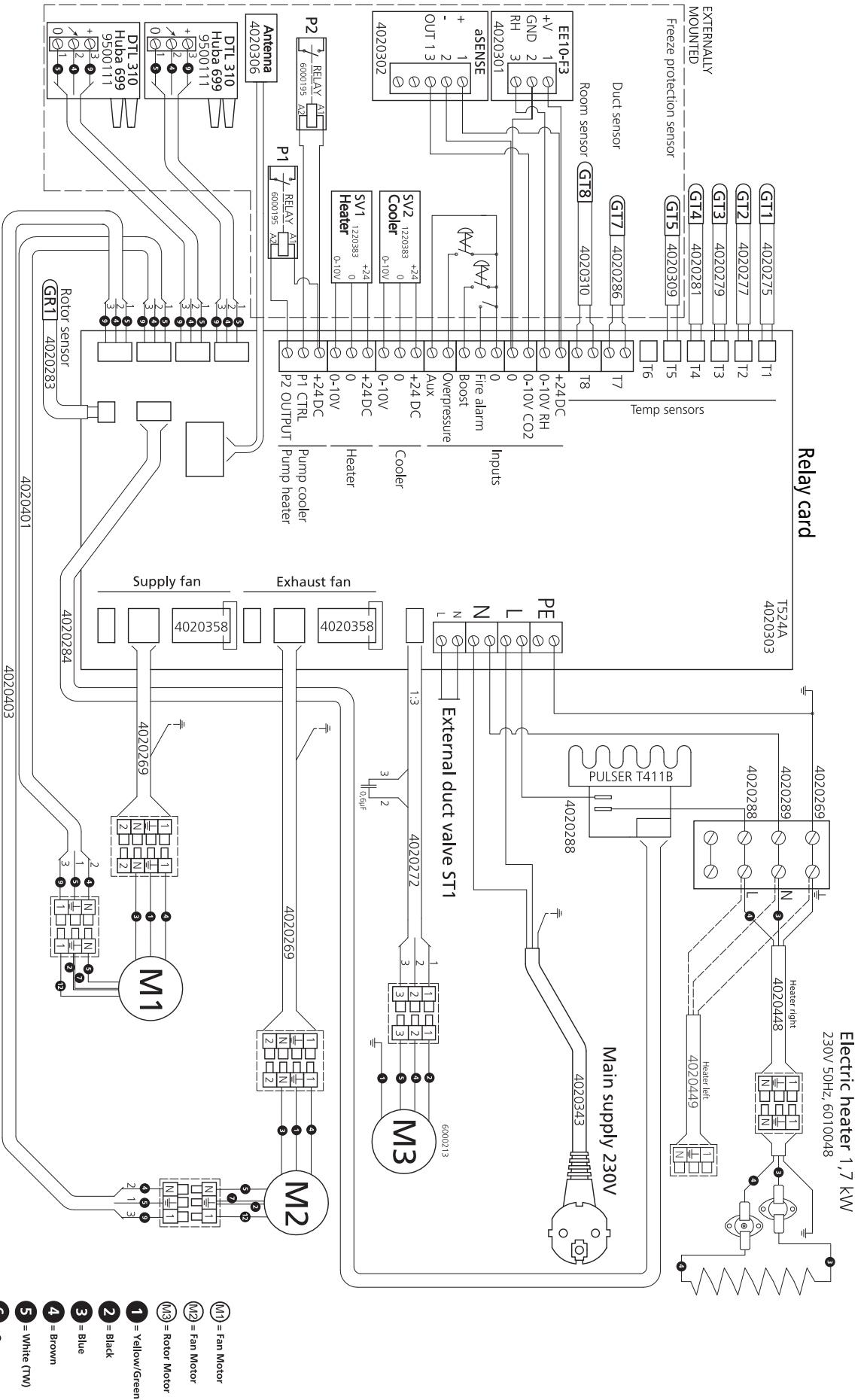

- (M1) = Fan Motor
- (M2) = Fan Motor
- (M3) = Rotor Motor
- 1 = Yellow/Green
- 2 = Black
- 3 = Blue
- 4 = Brown
- 5 = White (TV)
- 6 = Orange
- 7 = Grey
- 9 = Green
- 10 = Violet
- 12 = Yellow

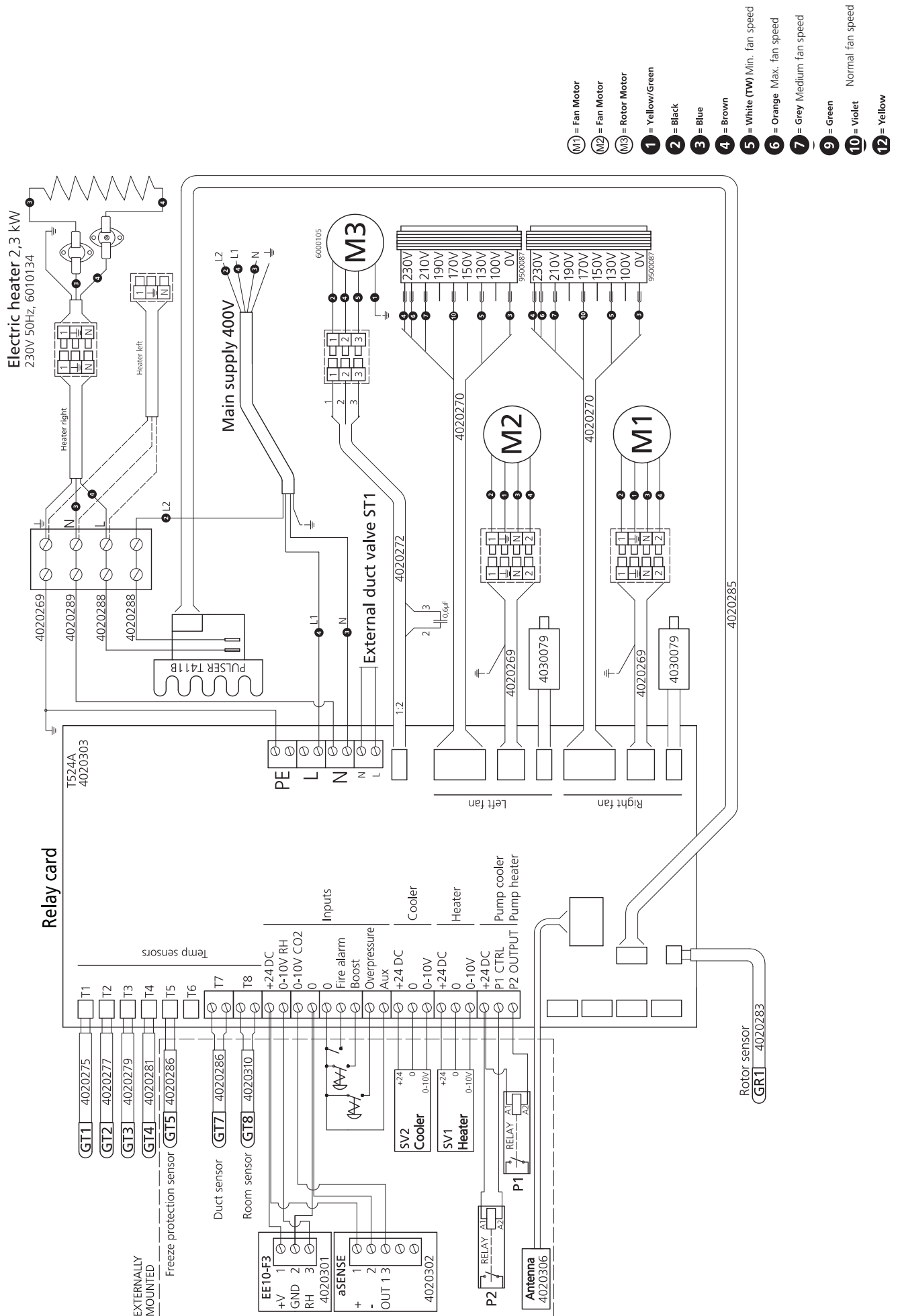

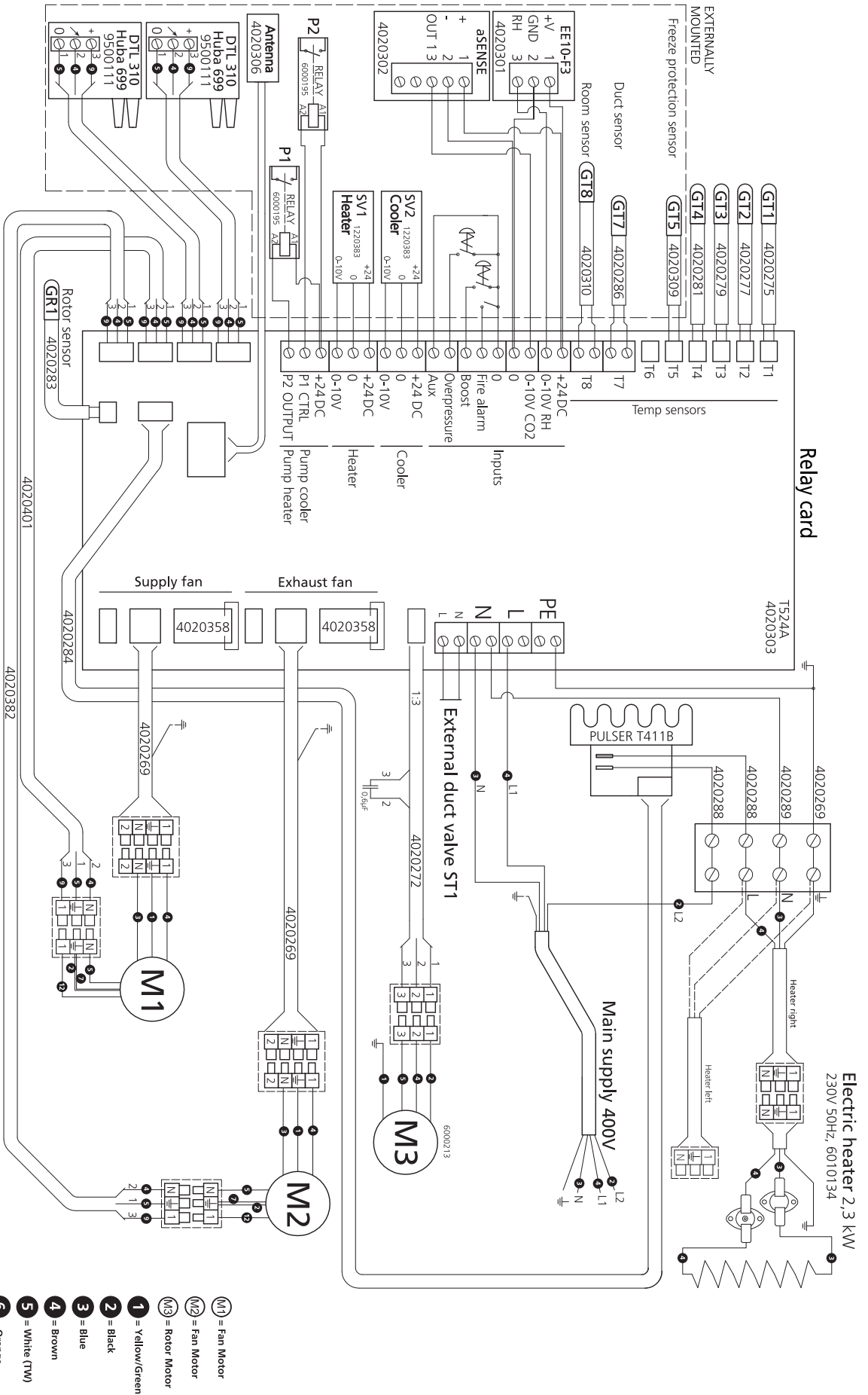

- ⊙ M1 = Fan Motor
- ⊙ M2 = Fan Motor
- ⊙ M3 = Rotor Motor
- ① = Yellow/Green
- ② = Black
- ③ = Blue
- ④ = Brown
- ⑤ = White (TW)
- ⑥ = Orange
- ⑦ = Grey
- ⑨ = Green
- ⑩ = Violet
- ⑫ = Yellow

## REGULATION FUNCTIONS

### REGULATE THE TEMPERATURE

The air temperature can be regulated either for constant supply air temperature, constant room temperature or constant exhaust air temperature.

For constant room temperature a sensor should be placed in the room for room regulation (this is also suitable when a cooling coil is incorporated in the system).

Exhaust air regulation functions in a similar way but with the difference being that the sensor is placed at the exhaust air of the unit.

The rotor always starts at an outdoor temperature below +14°C to avoid low supply air temperature and condensation as an effect.

The temperature can be regulated in 5 sequences:

1. **Cooling recovery + After cooling:** The regulation unit can regulate a cooling coil (e.g. cooling water from bedrock), when the cooling recovery from the rotor is not enough.
2. **Cooling recovery or regulated after cooling:** The rotary heat exchanger starts if the exhaust air temperature is lower than outside temperature.  
Regulated after cooling: The aftercooling starts when the outside temperature is lower than desired room temperature and is not enough to lower the room temperature.
3. **Outside temperature = desired temperature:** When the outside temperature is the same as desired supply air temperature the rotor stops.
4. **Heat recovery:** The rotary heat exchanger starts to recover the warmer room temperature.
5. **Heat recovery + heat:** In climate conditions where the rotary heat exchanger, in spite of its high efficiency, is not sufficient to reach the desired supply air temperature, the controller can regulate either the built-in electric duct heater or a heating coil.

### FAN CAPACITY

Airflow (fan speed) is regulated via the week timer that can be programmed for specific time points when the fan speed should change from one speed to another (e.g. home or away setting). A special feature is that you can pressure compensate when supplementary heating using an open fire or stove (the exhaust air fan then drops to a lower speed).

The wireless control unit can also manually adjust the fan speed and even boost the airflow for an indicated length of time. The fan speed can also be controlled by a carbon dioxide (CO<sub>2</sub>) and humidity (RH) sensor so that the unit gives a higher airflow (boost) when the maximum threshold is reached.

**Summer Cooling** is a function where you can use the cool outside temperature to cool down the inside air. The fan speed is forced when the ratio between the outside temperature and the exhaust air temperature is within the programmed criteria.

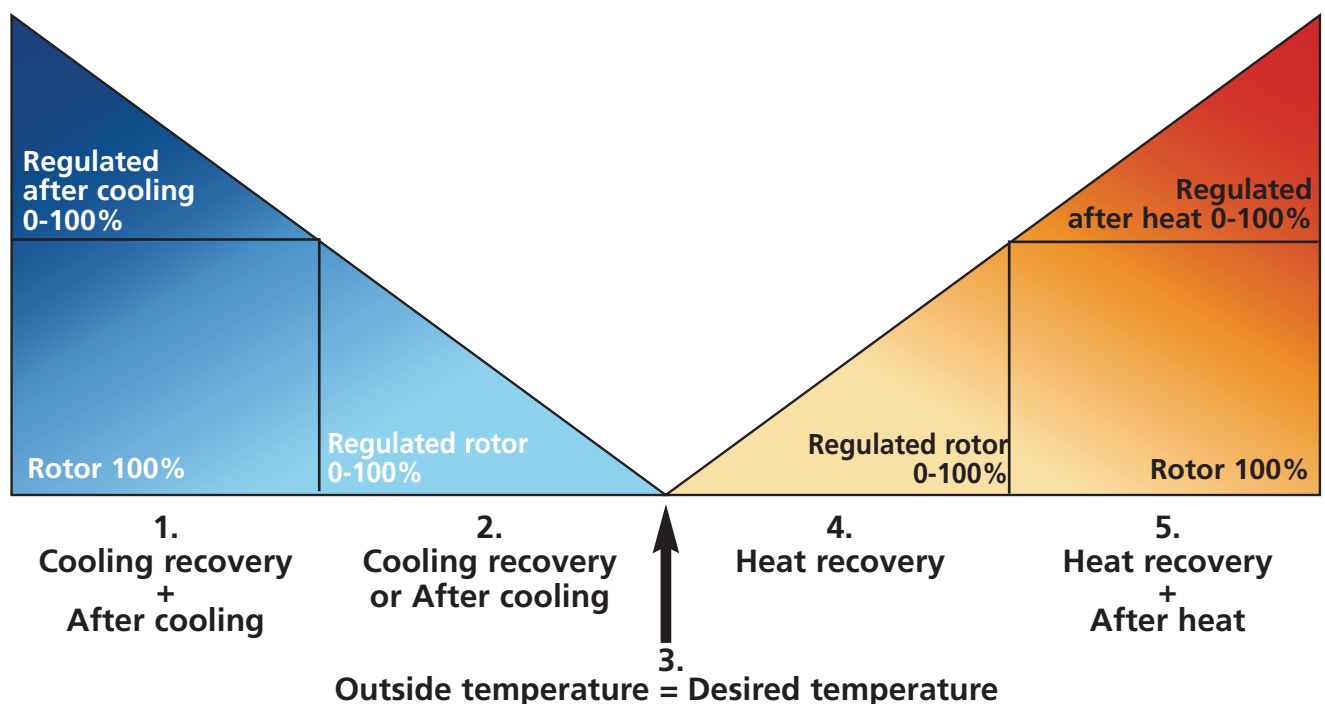

## OPERATING THE CONTROL UNIT

Information of the units current status such as temperature, fan speed, the rotor temperature efficiency when operating, heat respectively cooling needs is shown in the **VIEW MODE 1, 2, 3 and 4**. These menus is normally not lit up for battery-saving purposes but is lit up after the first press of the button and is switched off after about 2 minutes of not being in use.

The control unit automatically returns to **VIEW MODE 1** after one minute when one has viewed other submenus.

**NB!** At new setting a delay of 15 seconds should be taken into consideration.

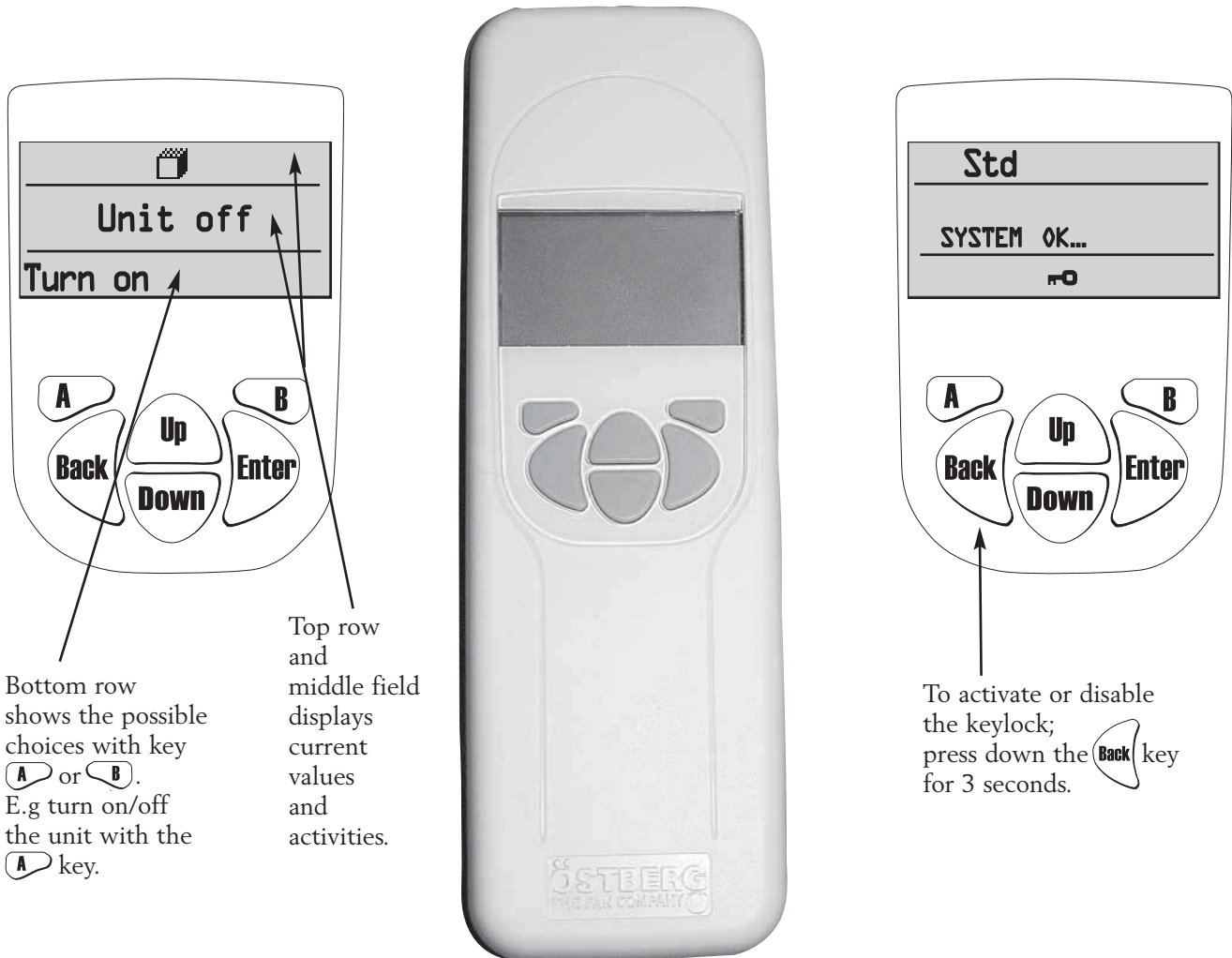

**VIEW MODE 1** shows alarm and **VIEW MODE 2** shows what kind of alarm.

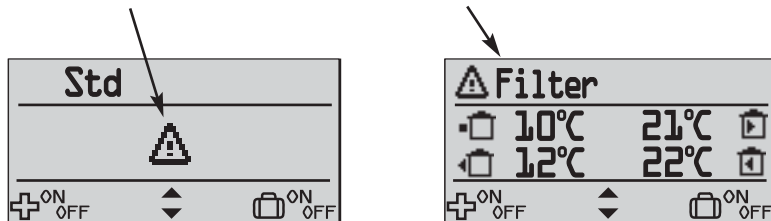



## VIEW MODE 1

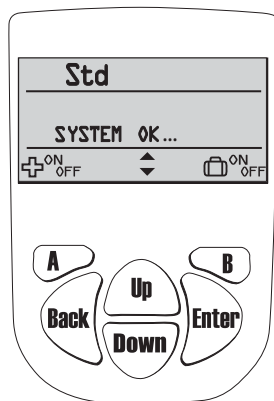

In order to go view mode 2, 3 or 4 press **Up** or **Down**.  
In order to return to view mode 1, press **Back**.

### SYMBOLS THAT CAN BE DISPLAYED IN VIEW MODE 1:

- = Indicates that the rotor is operating.
- = heat recovery
- = cooling recovery
- Std** = Fan speed. Choose from min, standard, medium, max.
- = The status of the heating coil. Symbol indicates heating demand.
- = Summer cooling is active.
- = Week timer is active.
- = Function of A-key. Press A-key to regulate "boost" of supply & exhaust air flow.
- = Function of B-key. Press B-key to turn off pressure compensation.
- = Function of B-key. Press B-key to choose "Away" on or off.
- = The status of the cooling coil. Symbol indicate there's a cooling demand.
- = Function of keys up and down for view mode 2, 3 and 4.
- = Alarm
- = Indicates Boost is active.
- = Indicates Away is active.
- = Pressure compensation is active.

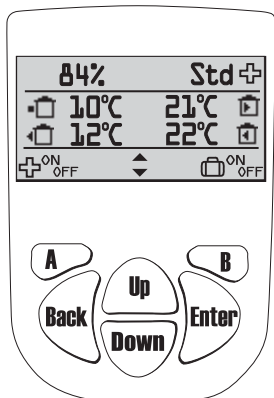

In order to go view mode 3 or 4 press **Up** or **Down**.  
In order to return to view mode 1, press **Back**.

## VIEW MODE 2

### SYMBOLS THAT CAN BE DISPLAYED IN VIEW MODE 2:

- = Indicates that the rotor is operating.
- = heat recovery
- = cooling recovery
- 84%** = Temperature efficiency.
- = The status of the heating coil. Symbol indicates heating demand.
- = The status of the cooling coil. Symbol indicate there's a cooling demand.
- = Week timer is active.
- = Summer cooling is active.
- = Outside temperature.
- = Extract air temperature.
- = Supply air temperature.
- = Exhaust air temperature.
- CO2** = CO<sub>2</sub> compensation is active.
- = Function of A-key. Press A-key to regulate "boost" of supply & exhaust air flow
- = Function of B-key. Press B-key to turn off pressure compensation.
- = Function of B-key. Press B-key to choose "Away" on or off.
- = Function of keys up and down for view mode 1, 3 and 4.
- = Alarm
- = Indicates Boost is active.
- = Indicates Away is active.
- = Pressure compensation is active.
- RH** = RH compensation is active.

IN VIEW MODE 1 AND 2 BOOST OFF/ON AND AWAY OFF/ON CAN BE CHOSEN.

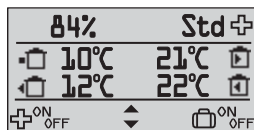

Press **A** key to choose **Boost off/on** of the supply & exhaust air flow for a specific time (time and fan speed settings during the boost is made in the Service menu "Boost" page 100).  
When the "plus" symbol is displayed in the right corner, the boost is activated.

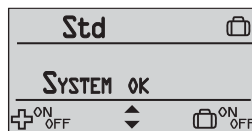

Press **B** key to choose **Away off/on**.  
When the symbol "suitcase" is displayed in the right corner, the away mode is activated, i.e. the fan speed is minimum.

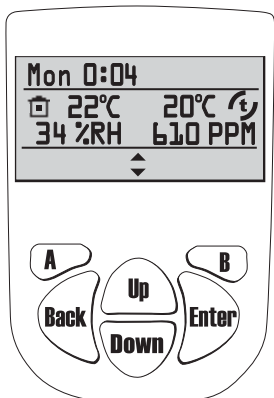

In order to go view mode 2 or 4 press **Up** or **Down**.  
In order to return to view mode 1, press **Back**.

## VIEW MODE 3

### SYMBOLS THAT CAN BE DISPLAYED IN VIEW MODE 3:

- Mon 0:04** = Display weekday and time.
- = Indicates that Summer cooling is active.
- = Indicates that week timer is active.
- = Room temperature. Sensor placed in room.
- 34 %RH** = Relative air humidity in per cent.
- 610 PPM** = Carbon dioxide level in PPM (part per million).
- 20°C** = Supply air temperature after the rotor.
- = Function of keys up and down for view mode 1, 2 and 4.
- = Indicates Boost is active.
- = Pressure compensation is active.
- CO2** = CO<sub>2</sub> compensation is active.
- RH** = RH compensation is active..

## VIEW MODE 4 (only Heru EC)

### SYMBOLS THAT CAN BE DISPLAYED IN VIEW MODE 4:

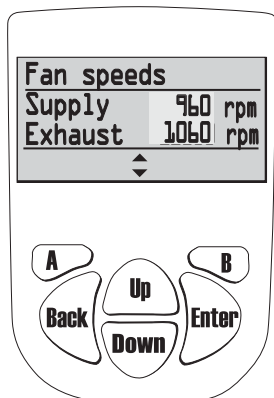

Displays fan speed of supply and exhaust air in rpm.  
At Constant pressure regulation the max speed, the fan speed and current pressure sensor value is displayed in per cent.



In order to go view mode 2 or 3 press **Up** or **Down**.  
In order to return to view mode 1, press **Back**.

## " MAIN MENU "





In order to go forward in the menu from the View mode to the **Main Menu** press .

In the **Main Menu**  is used to select the desired menu, after the choice is made with .

The procedure is the same in the submenu. In order to return to the previous page press .

## " FAN SPEED " MENU (Only for Heru®AC)

In this menu desired fan speed is chosen. You can choose from 4 speeds: **Min, Standard, Medium and Max.** Normal operation should be done in standard mode

Press  in order to go forward from the Main Menu. Press  again and then  in order to choose the desired fan speed. Confirm with .



For Heru EC, standard speed/mode during normal operation.

*Made settings is overridden if **Week Timer** is activated.*

## " TEMPERATURE " MENU

In this menu desired temperature is chosen (**supply air, exhaust air or room temperature**) depending on what kind of regulation that is chosen, see page 103.

Press  in order to go forward from the Main Menu. Press  again and then  in order to choose the desired temperature (15°C-40°C); .Confirm with .



*Made settings is overridden if **Week Timer** is activated.*

## " BOOST " MENU

In this menu **Boost On/Off** is chosen. The time has the factory setting of 30 min. and fan speed Medium. To adjust the fan speed and time, see page 100.

Boost is activated/disable (On/Off) with the  key.

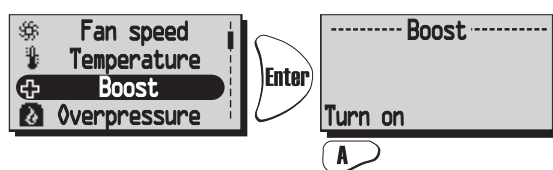

*The boost function can also be activate with an external switch with double pressure. See wiring diagram page 81-90.*

## "OVERPRESSURE" MENU

In this menu **Overpressure On/Off** is chosen. The time has the factory setting of 15 min. To adjust the time, see page 100.

Overpressure is activated/disable (On/Off) with the **A** key.

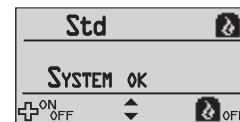
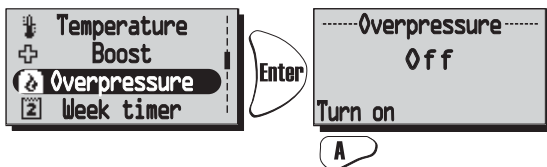

When pressure compensate is activated the symbol "Away" will be change to the symbol "Overpressure" in View mode 1 and 2. Than press **B** directly in the View mode to turn off Overpressure.

## "WEEK TIMER" MENU

When in normal operation the unit runs with the fan speed that was chosen in the "Fan Speed" menu and the temperature that was chosen in the "Temperature" menu. A departure from these programmed values that you periodically want to recall is done in this menu. For example if you want to have a lower flow/temperature during the daytime when nobody is at home then there is the possibility to adjust this here.

**Week timer.** If end time is the same or less than start time the program will end the following day.

Press **Enter** in order to go forward from the Main Menu.

Press **Enter** again and then **Up/Down** in order to choose **off/on** of the week timer. Confirm with **Enter**.

Press **Down** to choose/adjust the desired **program**. There are 5 programs for the adjustment of the fan speed and temperature available. Press **Up/Down** to choose a **program**.

Press **Enter** in order to go forward to choose a **weekday, start time, end time, fan speed and temperature**.

Use the keys **Up/Down** to choose the settings of weekday, start time, and end time, fan speed (Min, Standard, Medium, Max) and temperature (15°C-40°C).

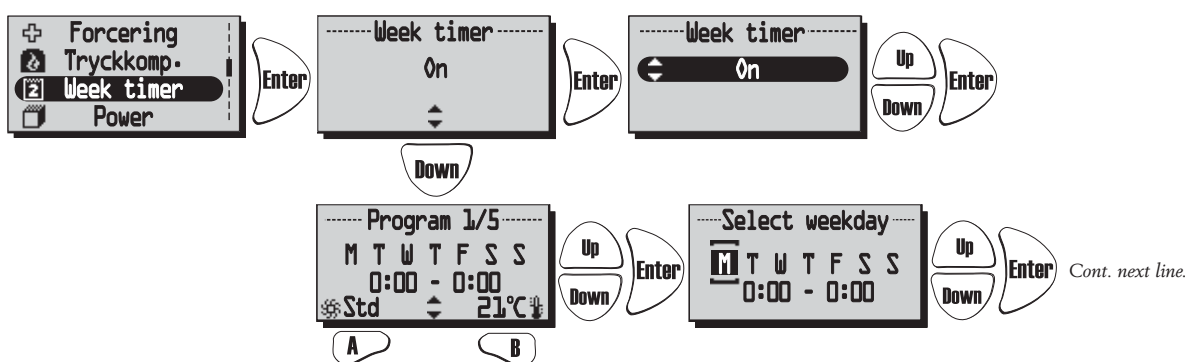

Cont.

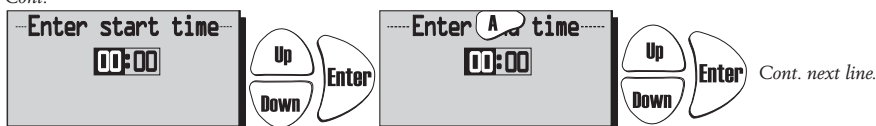

Cont

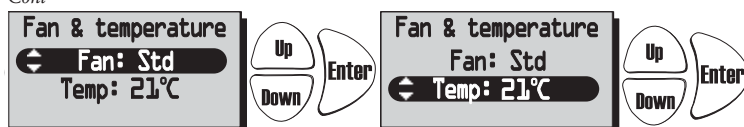

N.B! The activated **Week Timer** is overridden manual settings of fan speed and temperature.

## "UNIT ON/OFF" MENU

In the "Unit On/Off" Menu you have the possibility of turning off the unit via the wireless control unit.  
*NB! The unit must be currentless during service and maintenance.*

Press **Enter** in order to go forward from the Main Menu. Press **A** in order to choose on/off of the unit.

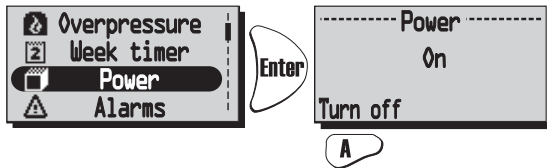

To avoid condensation in the unit during the cold season the unit should not be turned off for a longer period.

## "ALARMS" MENU

This meny displays alarms.

View mode 1 shows alarm and

View mode 2 shows what kind of alarm.

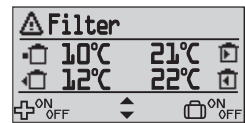
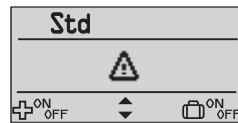

Alarms is shown for:

- "Rotor failure" • "Supply temp. low" • "Rotor temp. low" • "Fire alarm" • "Freeze alarm"
- "Sensor open" • "Sensor shorted" • "Overheating" • "Filter alarm" • "Fan failure" • "Filtertimer"

Press **Enter** in order to go forward from the Main Menu and to view status. If no alarm "System OK" is displayed.



When alerting a dialogue box for the alarm is shown in the Main Menu and the display will flash.  
 "View alarms" is shown and the possibility for equalization is given.

Press **A** to see the cause of alarm in a submenu. Control the cause and remedy the alarm.

Press **Down** to "Clear all" and than **Enter**.

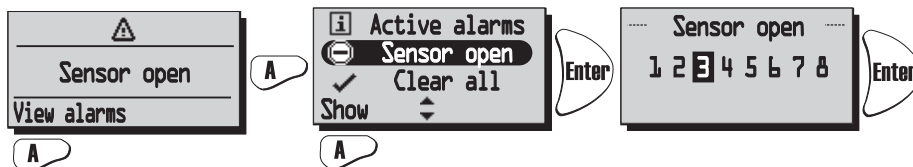
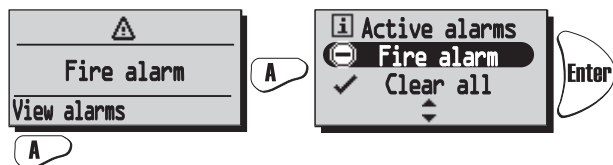

Current alarm is viewed. When "Sensor open" and "Sensor shorted" press **A** "Show" to view which sensor GT 1-8 is alerting.  
 See Control diagrams on page 79-80.

In order to return to the previous pages press **Back**.

When alarm for Filter timer the alarmet can equalize with Reset.  
 A reminder to change filter comes with a seven-day interval.  
 To restart the timer see "Service Menu Alarm" page 101.





## “SETTINGS” MENU

In this menu settings for **weekday**, **time** and what **language** is made.

Press  in order to go forward from the Main Menu. Press  again and then  in order to choose **weekday**.

Press  again and then  in order to enter the **time**.

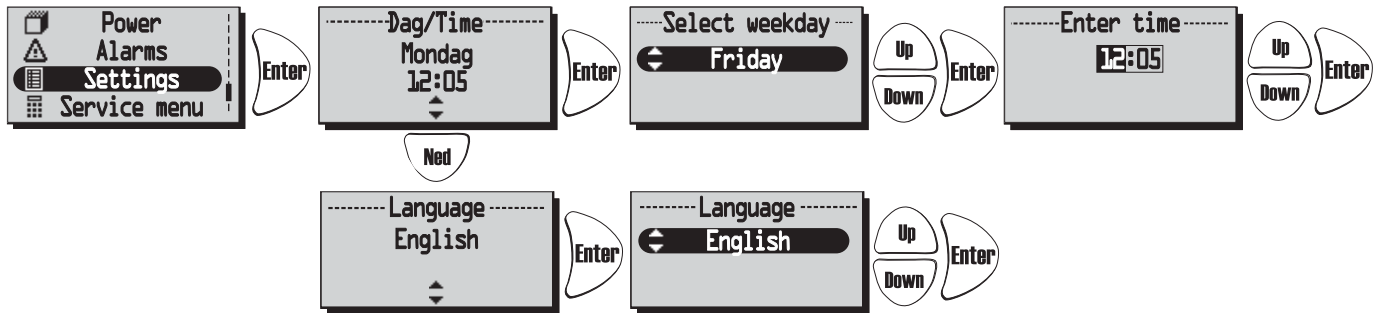

Press  and then  in order to choose a **language**. 4 languages are available: Swedish, Finnish, German and English.





## THE “SERVICE MENU”

In this menu a password is required in order to make adjustments. The password is 1199 and it can not be changed.



Press  in order to go forward from the Main Menu.

The password is entered with the  keys and every number is confirmed with .

After the password 1199 to the Service Menu the question “Are you sure?” will be displayed.

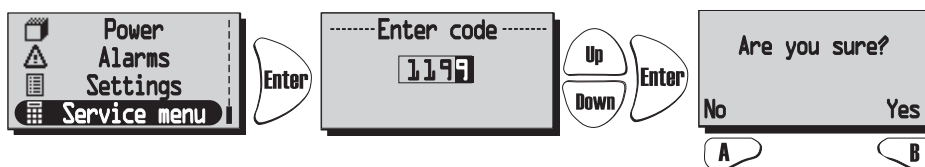
Press  for “No” or  for “Yes”.



To go further to the different functions in the “Service menu” press  or .

**SERVICE MENU: "CONSTANT PRESSURE (Only for Heru®EC)**

CPC (Constant Pressure Control) is set by the installer and should not be change. CPC can only be used with pressure sensor in the supply and exhaust duct. See page 73 for activation of installed sensor.

"Are you sure?" Press **A** or **Back** to return, or press **B** to make settings.

"Const. pr." If constant pressure not is activated this can now be done by pressing **A**. Go to settings for CPC with key **B**, or diable constant pressure with **A**.

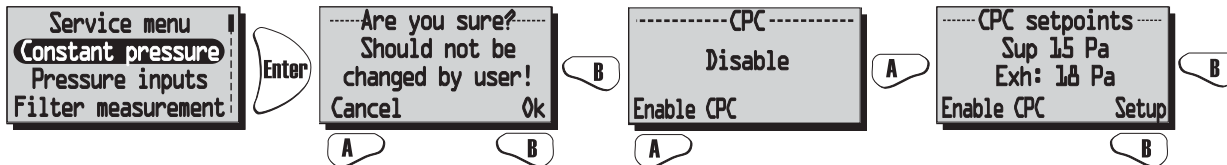

Set the speed 0-100% with **Up/Down** for both fans. Change between supply air and exhaust air with **Enter** or **A**, the current pressure is viewed. *NB! After changing the pressure settings, please wait until it has stabilized.*

When adjusting, the fans have constant speed and starts to regulate after the settings are saved, by pressing **B**.

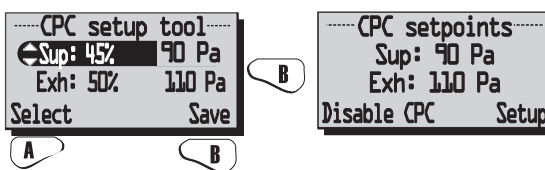

**SERVICE MENU: "PRESSURE INPUTS"**

HERU®EC: If a pressure sensor is installed a compatible range of pressure sensor can be set; -50/+50 Pa; 0/100 Pa; 0/150 Pa; 0/300 Pa; 0/500 Pa; 0/1000 Pa; 0/1600 Pa och 0/2500 Pa.

Sensors with the same range must be installed at the supply and exhaust air side.

The signal from the pressure sensor is 0-10 V DC.

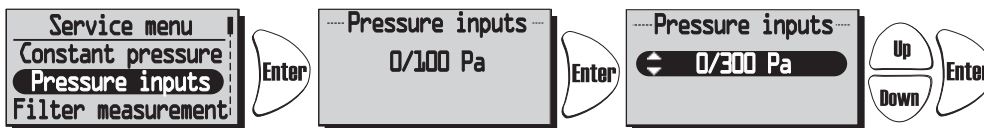

HERU®AC: If filter switches are installed these can be activated in this menu.

If "None" is set, the filter measurement is automatically deactivated.

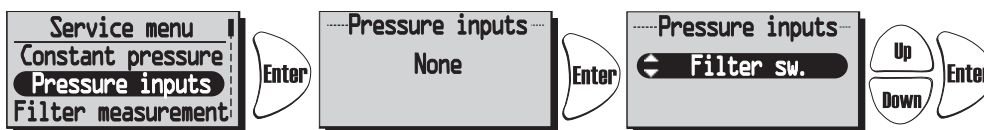

**SERVICE MENU: "FILTER MEASUREMENT"**

HERU®EC: The filter measurement can only be activated if pressure sensor is installed and CPC (Constant Pressure Control) is activated.

Alarm is displayed when the fan speed increased with set value. In this case with 15% to keep constant pressure in duct. It is possible to choose 5-50% increased speed or "Off" to deactivated.

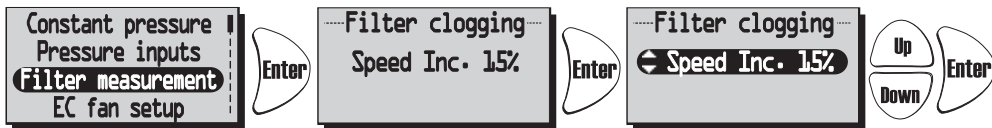

HERU®AC: If filter switches is installed and activated, setting for day and time is chosen when the unit should boost to measure increased pressure over supply air filter GP1 and exhaust air filter GP2.

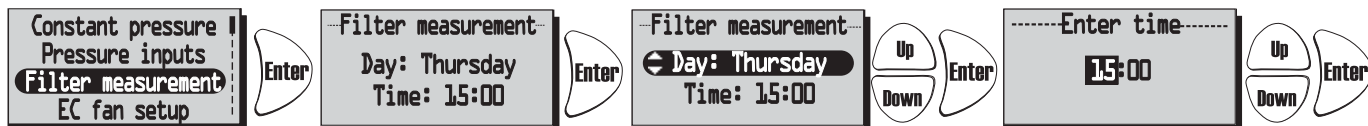

If no filter switches or pressure sensor are installed this is displayed:

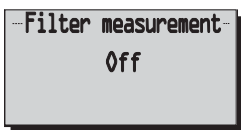

**SERVICE MENU: "EC FAN SETUP": (Only for Heru®EC)**

Fan speed settings for EC fans. No CPC.

The relationship between supply and exhaust air is also retained at the other speeds. The ratio between supply and exhaust air is adjusted only in standard mode.

CPC (Constant Pressure Control) deactivated.

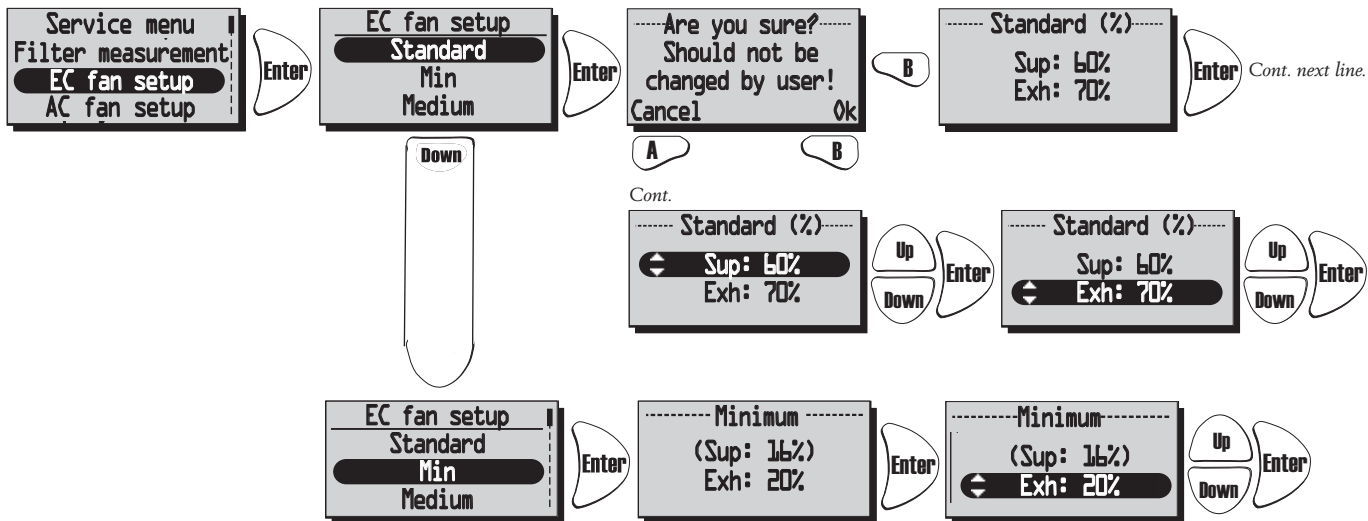

With the CPC activated the set value is displayed (current value). To change set value choose "To Constant pressure". See "Constant pressure" page 98.

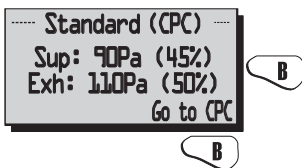

**SERVICEMENY: "AC FAN SETUP": (Gäller endast Heru®AC)**

When adjusting the unit, the speed is set to standard and functions that may affect the fan speed, such as "Away" and "Boost", should be inactivated.



### SERVICE MENU: "DISPLAY CONTRAST"

Display contrast setting. The contrast can be set between 0-63.



### SERVICE MENU: "BOOST":

Time settings for **Boost** and **Fan speed**. Boost means that during a specific time increases the air flow. This boost can then be activated at the View mode 1 and 2, and in the Main Menu "Boost".

Press **Enter** in order to go forward from the Main Menu. Press **Enter** again and then **Up/Down** in order to choose the desired **duration**. (10-240 min. with the interval of 10 min.)

Press **Enter** on order to confirm and go forward to fan speed.

Choose the desired **fan speed** with **Up/Down** (medium or max) and confirm with **Enter**.

Boost is activated/disable (on/off) with the **A** key.

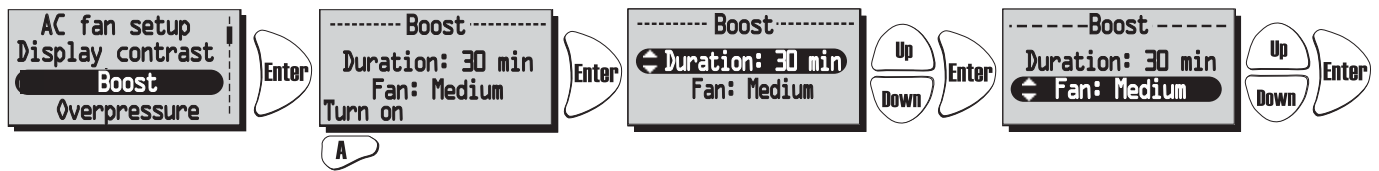

### SERVICE MENU: "OVERPRESSURE"

Time settings for **Overpressure**. Overpressure compensate is a special feature when supplementary heating using an open fire or stove (the exhaust air fan drops to a lower speed during a specific time).

Press **Enter** in order to go forward from the Main Menu. Press **Enter** again and then **Up/Down** in order to choose the desired **duration** (5-60 min.).





**SERVICEMENY: "ALARM"**

In this menu alarm limits is set for **Filter timer**, **Low temperature** and setting for **Fire sensor**.

"**Filter timer**" can be set from "Off" to "6-12 months" and generates alarm for filter change. Filter timer can not be used in combination with another filter measurement, see page 73. We recommend filter change at least once a year.

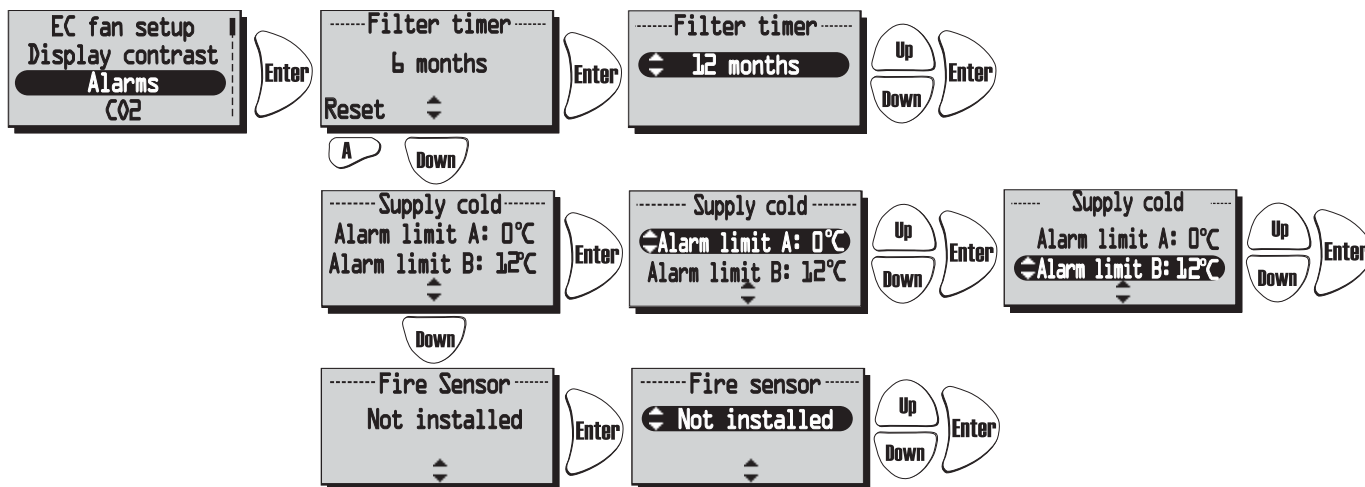

To restart the filter timer press "Reset" with the **A**-key.

Alarm limits for "Low temperature".

**Alarm limit A:** (+2 till +10°C but must be lower than "Alarm limit B")

Alarm for low rotor temperature is displayed when the temperature is lower than set value. Normally nothing needs to be done. If "Rotor Alarm" appears at the same time as "Rotor temp. Low" the unit is stopped.

**Alarm limit B:** Supply air flow is reduced with one step when the temperature in supply air duct (GT7) is lower than set value, and the temperature efficiency increases (the temperature can be change from +5 to +12°C but have to be higher than "Alarm limit A").

If the unit operating at Min. speed the exhaust air increases one step.

In menu "Fire sensor" type of installed fire sensor is set.

Choose "Normally open" NO or "Normally closed" NC depending on the type of smoke detector.

**SERVICEMENY: "CO2"** Carbon dioxide level in PPM (part per million).

In this menu settings are made for regulation with installed CO2 sensor.

Press **Enter** again and then **Up/Down** in order to choose the Limit value (500-1400 PPM).

HERU®EC: Press **Enter** again and then **Up/Down** in order to choose Ramp (2-200%/h.).

At levels above the limit value the fan speed will increase according to the set Ramp value. In the example below the fan speed will increase with 10% per hour when the carbon dioxide level in the air is higher than 900 PPM.

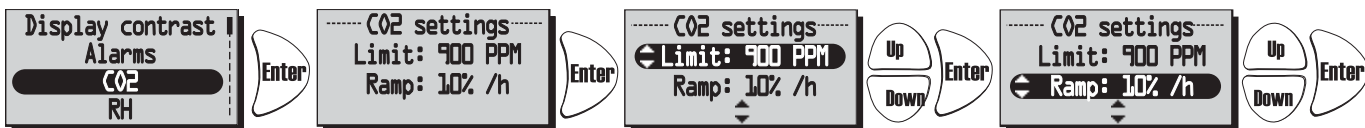

HERU®AC: Press **Enter** again and then **Up/Down** in order to choose Interval (1-10 min.).

At levels above the limit value the fan speed will increase one step according to the set Interval value.



Measured CO2 value is displayed in View mode 3, see page 93.

## SERVICEMENY: "RH" Relative air humidity in percent

In this menu settings are made for regulation with installed RH sensor.

Press again and then in order to choose the **Limit value of boost** (50%-100%).

HERU®EC: Press again and then in order to choose **Ramp** ( 2-200%/h.).

At levels above the limit value the fan speed will increase according to the set Ramp value. In the example below the fan speed will increase with 10% per hour when the relative air humidity level is higher than 70%.

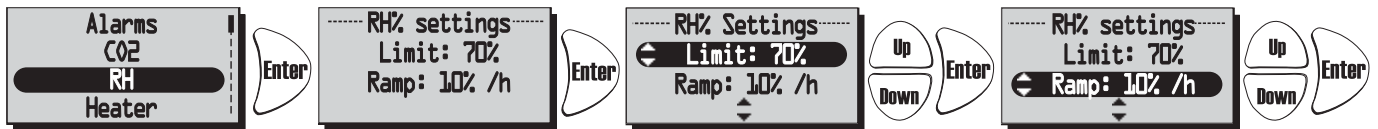

HERU®AC: Press again and then in order to choose **Interval** (1-10 min.).

At levels above the limit value the fan speed will increase one step according to the set Interval value.



Measured RH value is displayed in View mode 3, see page 93.

## SERVICEMENY: "HEATER"

In this menu type of Heater is chosen to be activated.

If a heating coil is used a freeze protection sensor (GT5) must be installed, and a damper ST1 must be mounted in the fresh air duct. The GT7 must be mounted after the Heater.

Press again and then in order to choose On or Off.

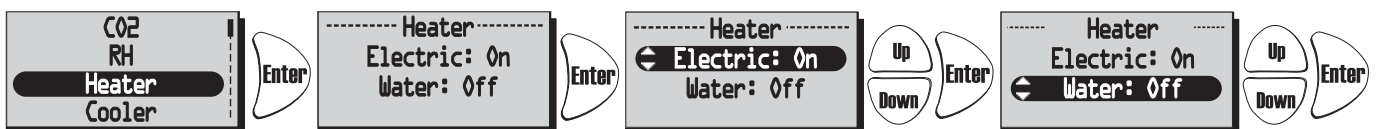

## SERVICEMENY: "COOLER"

In this menu a cooling coil can be activated if installed.

Press again and then in order to choose On or Off.



### SERVICEMENY: "SUPPLY LIMITS"

In this menu the upper and lower limit value for the supply air temperature at room or exhaust air regulation is set.

Press again and then in order to choose a **minimum limit value** (15°C-19°C).

Press again and then in order to choose a **maximum limit value** (20°C-40°C).



### SERVICEMENY: "REGULATION MODE"

3 different types of regulation modes can be used.

- At a **constant supply air regulation** the temperature sensor (GT7) is placed in the supply air duct and a constant incoming air temperature is obtained.
- At **room regulation** a sensor (GT8) is placed in the room and a sensor (GT7) in the supply air duct (minimum/maximum limitation) and then a constant room temperature is obtained (suitable when a cooling coil is installed).
- The **exhaust air regulation** functions in a similar way to the room regulation with the difference being that the temperature is measured in the exhaust air duct.

Press again and then in order to choose **Supply reg.**, **Exhaust reg.** or **Room reg.**

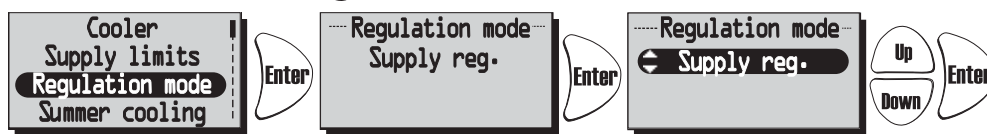

### SERVICEMENY: "SUMMER COOLING"

If "Summer Cooling" "On" is chosen, the Summer cooling is activated when the exhaust air temperature is higher than "Exhaust HI" (19°C-26°C) and outside air is colder than "Exhaust - 'In OutDiff' (1°C-10°C difference between the temperature outside and exhaust air)".

Summer cooling is deactivated when exhaust air temperature is lower than "Exhaust LO" (18°C-24°C) or when the outside temperature is warmer than "Exhaustair - 'InOutDiff + 1,0°C'".

Press again and then in order to choose **On** or **Off**. In order to go forward in "Summer Cooling" press .

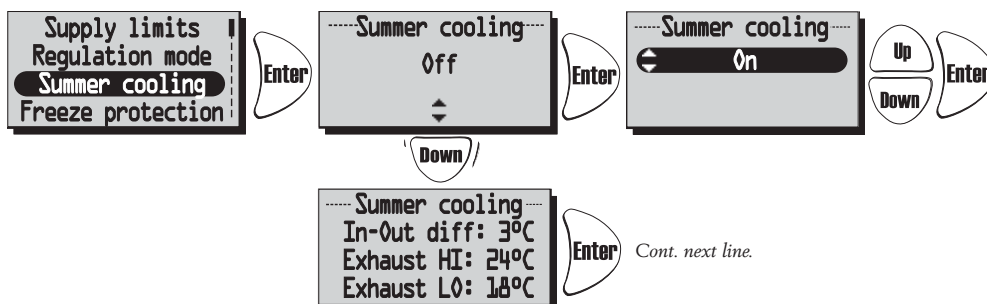

Cont.

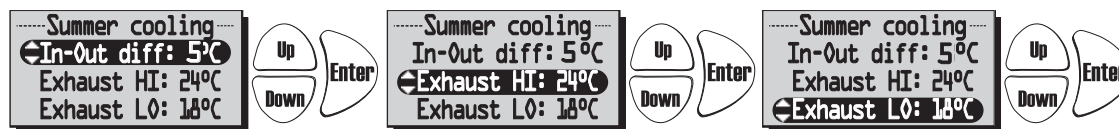

Press again and then in order to choose 'InOutDiff': (1°C-10°C), **Exhaust HI**: (19°C-26°C) and **Exhaust LO**: (18°C-24°C).

**SERVICEMENY: "FREEZE PROTECTION"**

Setting of limit value when freeze protection sensor is installed. The sensor (GT5) is installed on the return pipe from the heating coil. When 3°C higher than set point the valve opens completely. If the temperature continues to fall to set point the unit will stop.

Press again and then in order to choose Limit: (5°C-10°C).



**SERVICEMENY: "FLOW DIRECTION"**

HERU S A2: Make settings if the supply air and exhaust air is connected on the right or left hand.  
Supply air and exhaust air must be connected on the same side of the unit.

HERU T: is delivered for right handed application only.

Press again and then in order to choose Left or Right.



**SERVICEMENY: "LOAD/SAVE SETTINGS"**

"Load/Save" gives the installer the opportunity to save the set values in service menu after the installation, alt. load previously saved values.

Press again and then in order to choose Load Settings or Save settings.

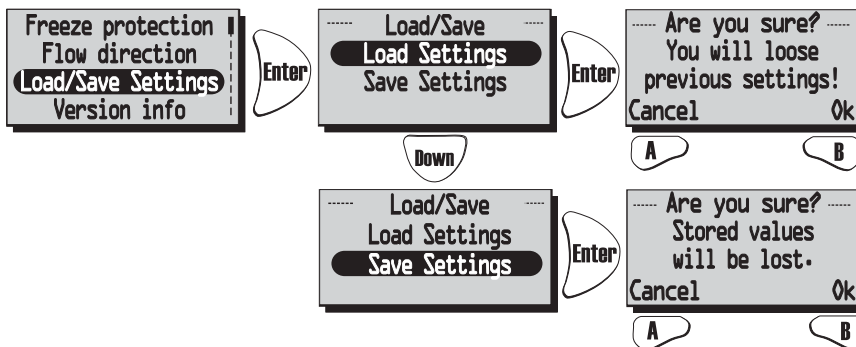

After you have "load" or "Saved" it may take a minute before the unit re-created connection to the wireless control unit and the right data is displayed.

**SERVICEMENY: "VERSION INFO"**

Displays the software version of the unit (Heru) and the wireless control (RC).

Press again to see the version.

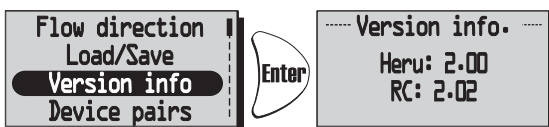

## SERVICEMENY: "DEVICE PAIRS"

In this menu, looking for the wireless control unit the frequency control unit on the unit uses. This procedure must be used e.g. when a new wireless control unit states obtained.

### Connecting a new wireless control unit:

Cut the power to the unit and allow it to stand the rejection of an hour. Before the unit is connected, press "Start" with the **A** key in the "Device pairs" menu, and connect the unit within 20 seconds.

Within seconds you will return to "Service menu" and the wireless control unit is connected.

If you end up in "Device pairs" instead of "Service menu" the connection has failed. Try one more time.

If the wireless control unit has been used in an assembly earlier, it will say "Synchronize" instead of "Start".

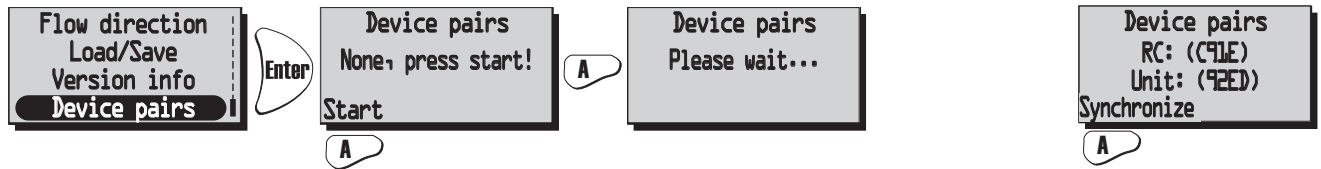

## OTHER FUNCTIONS

- Function test of rotor motor.  
The rotor runs for three minutes every day at 12.03, if the rotor has not been operate for 24 hours.
- Function test of radiator valves and cirkulation pump.  
Once a week (Mondays at 12.09) there is a maintenance program running in order to secure functions of valves and pumps.

# DIMENSIONS

## HERU®90 T EC

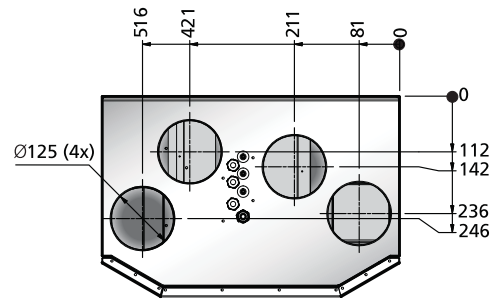
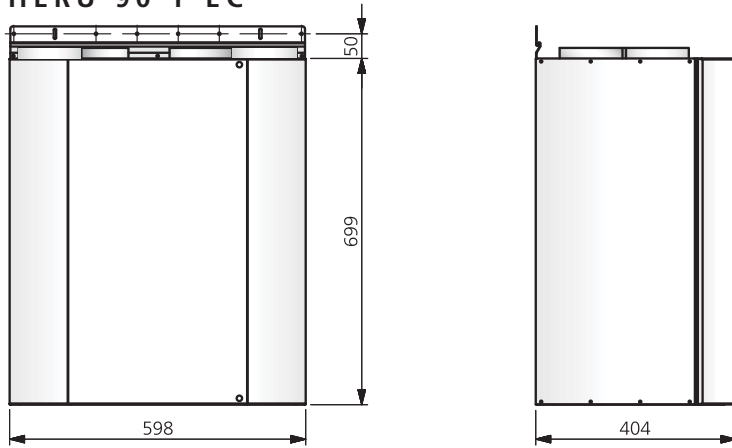

## HERU®130 T EC

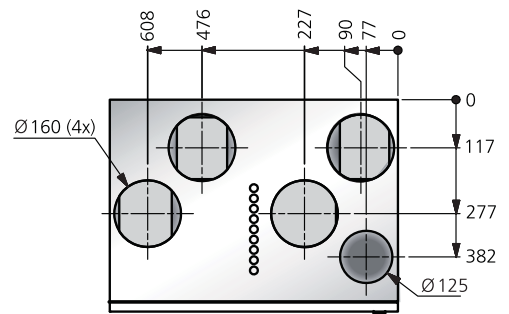
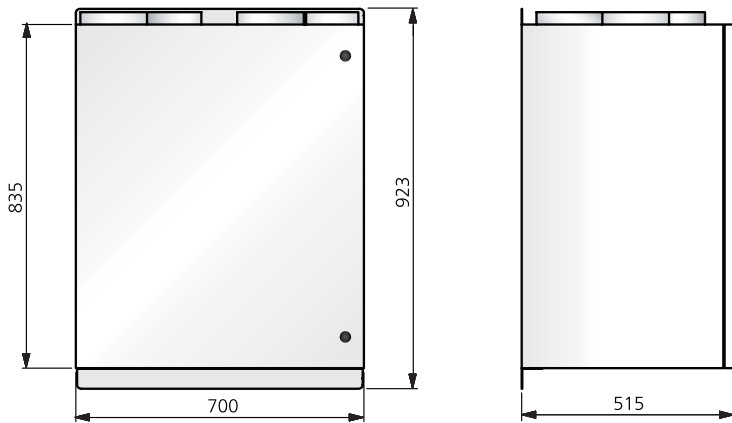

# DIMENSIONS

## HERU®50 S/ 75 S/90 S EC

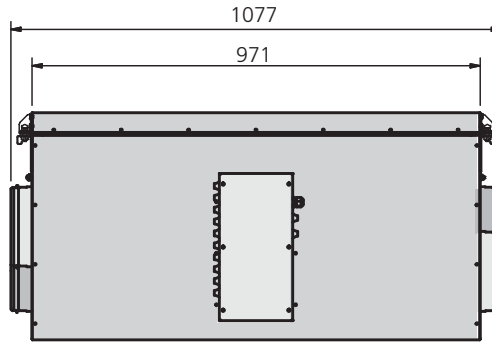
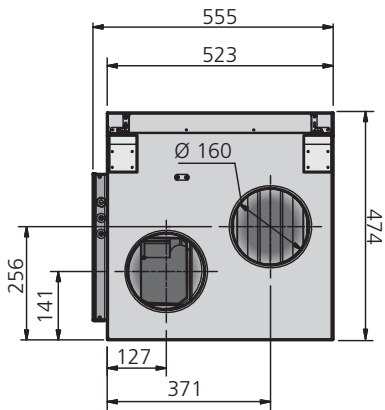

## HERU®130 S/130 S EC

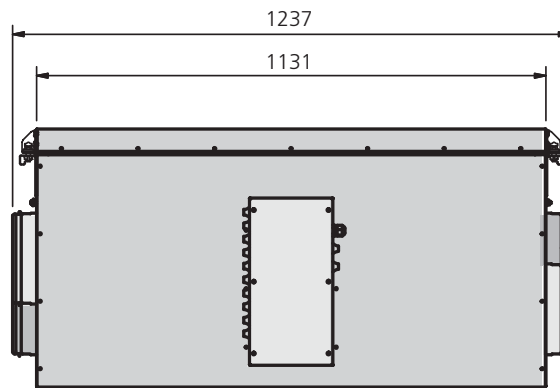
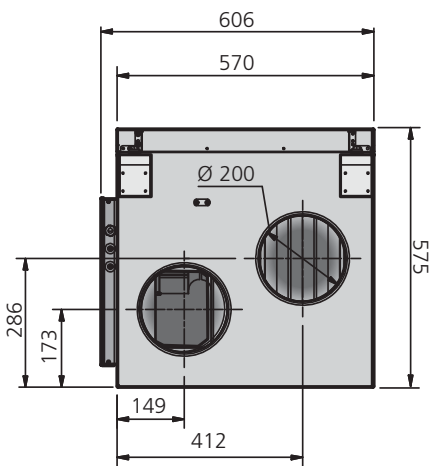

## HERU®180 S/180 S EC

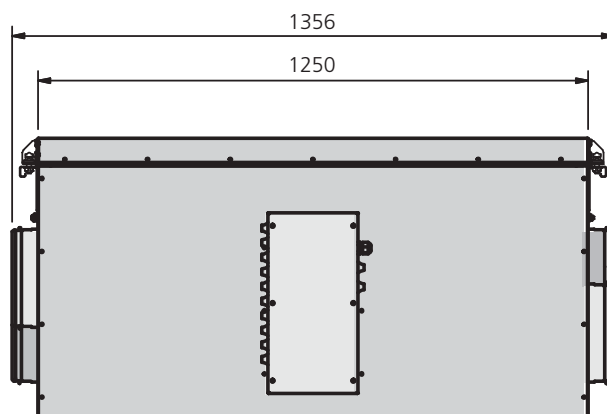
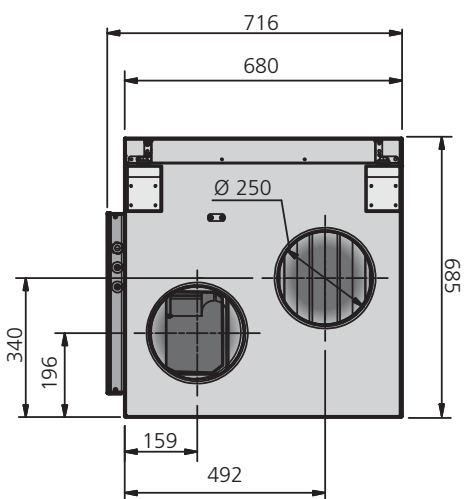

# TECHNICAL DATA

Data stated at 100 Pa external pressure drop. See below for explanation of Sound pressure level.

## HERU®62 T

Voltage V/Hz	Fan Current A	Total Current A	Fan input W	Total input W	SFP kW (m³/s)	Input electric heater W/A	Sound pressure level L <sub>pA</sub>	Weight kg	Duct connection mm
230/50	0,5	5,8	109	1336	1,8	1200/5,2	43	54	Ø125

## HERU®90 T

Voltage V/Hz	Fan Current A	Total Current A	Fan input W	Total input W	SFP kW (m³/s)	Input electric heater W/A	Sound pressure level L <sub>pA</sub>	Weight kg	Duct connection mm
230/50	1,2	6,5	275	1502	3,0	1200/5,2	43	54	Ø125

## HERU®90 T EC 2

Voltage V/Hz	Fan Current A	Total Current A	Fan input W	Total input W	SFP kW (m³/s)	Input electric heater W/A	Sound pressure level L <sub>pA</sub>	Weight kg	Duct connection mm
230/50	1,4	6,7	164	1391	2,0	1200/5,2	47	53	Ø125

## HERU®115 T

Voltage V/Hz	Fan Current A	Total Current A	Fan input W	Total input W	SFP kW (m³/s)	Input electric heater W/A	Sound pressure level L <sub>pA</sub>	Weight kg	Duct connection mm
230/50	1,0	8,5	220	1947	2,0	1700/7,4	47	81	Ø160

## HERU®130 T EC

Voltage V/Hz	Fan Current A	Total Current A	Fan input W	Total input W	SFP kW (m³/s)	Input electric heater W/A	Sound pressure level L <sub>pA</sub>	Weight kg	Duct connection mm
230/50	2,0	9,5	226	1953	1,7	1700/7,4	54	80	Ø160

## HERU®140 T

Voltage V/Hz	Fan Current A	Total Current A	Fan input W	Total input W	SFP kW (m³/s)	Input electric heater W/A	Sound pressure level L <sub>pA</sub>	Weight kg	Duct connection mm
230/50	1,5	9,0	335	2062	2,3	1700/7,4	47	81	Ø160

## HERU®50 S 2A

Voltage V/Hz	Fan Current A	Total Current A	Fan input W	Total input W	SFP kW (m³/s)	Input electric heater W/A	Sound pressure level L <sub>pA</sub>	Weight kg	Duct connection mm
230/50	0,7	5,9	140	1367	2,6	1200/5,2	40	63	Ø160

## HERU®75 S 2A

Voltage V/Hz	Fan Current A	Total Current A	Fan input W	Total input W	SFP kW (m³/s)	Input electric heater W/A	Sound pressure level L <sub>pA</sub>	Weight kg	Duct connection mm
230/50	1,1	6,3	217	1444	2,9	1200/5,2	44	63	Ø160

## HERU®90 S EC 2A

Spänning V/Hz	Fläktström A	Totalström A	Fläkteffekt W	Total effekt W	SFP kW (m³/s)	Effekt elvärmare W/A	Ljudtrycksnivå L <sub>pA</sub>	Vikt kg	Kanal- anslutning mm
230/50	1,4	6,7	164	1391	1,7	1200/5,2	47	62	Ø160

## HERU®130 S 2A

Voltage V/Hz	Fan Current A	Total Current A	Fan input W	Total input W	SFP kW (m³/s)	Input electric heater W/A	Sound pressure level L <sub>pA</sub>	Weight kg	Duct connection mm
230/50	1,4	8,8	308	2035	2,5	1700/7,4	42	100	Ø200

## HERU®130 S EC 2A

Voltage V/Hz	Fan Current A	Total Current A	Fan input W	Total input W	SFP kW (m³/s)	Input electric heater W/A	Sound pressure level L <sub>pA</sub>	Weight kg	Duct connection mm
230/50	2,0	9,5	232	1959	1,6	1700/7,4	48	99	Ø200

## HERU®180 S 2A

Voltage V/Hz	Fan Current A	Total Current A	Fan input W	Total input W	SFP kW (m³/s)	Input electric heater W/A	Sound pressure level L <sub>pA</sub>	Weight kg	Duct connection mm
230/50	1,8	11,8	396	2723	2,0	2300/10,0	43	136	Ø250

## HERU®180 S EC 2A

Voltage V/Hz	Fan Current A	Total Current A	Fan input W	Total input W	SFP kW (m³/s)	Input electric heater W/A	Sound pressure level L <sub>pA</sub>	Weight kg	Duct connection mm
230/50	2,0	12,1	230	2557	1,4	2300/10,0	52	135	Ø250

The sound data have been compiled by means of sound measurement methods as follows: Pressure and flow: SS-ISO 5801. Determination of acoustic sound power level in duct: SS-ISO 5136. Determination of acoustic sound power level in reverberation room: SS-EN ISO 3741.

### DESIGNATIONS

The table on the right present the total A-weighted sound power level,  $L_{WA}$ , as well as in octave bands in dB(A) (ref 10<sup>-12</sup>W). In the "Technical Data" above, the total sound pressure,  $L_{pA}$ , calculated from the total

surrounding sound power level,  $L_{WA}$ , at 230 V is presented in dB(A) (ref 20 x 10<sup>-6</sup>Pa). The relation between sound pressure and sound power is

$$L_{pA} = L_{WA} + 10 \times \log \left( \frac{Q}{4\pi r^2} + \frac{4}{A_{Ekv}} \right)$$

where  $Q$  is the propagation factor,  $r$  is the distance from the unit and  $A_{Ekv}$  is the equivalent absorption area.

When calculating the  $L_{pA}$  it has been assumed that  $Q=2$ ,  $r=3$  m and  $A_{Ekv}=20$  m<sup>2</sup>, which gives  $L_{pA} \approx L_{WA} - 7$ .



# SOUND DATA

## HERU®62 T

230 V / 63 l/s	Total (L <sub>WA</sub> )	63 Hz	125 Hz	250 Hz	500 Hz	1k Hz	2k Hz	4k Hz	8k Hz
Surrounding	50	34	39	49	42	38	38	34	29
Supply	71	55	59	68	63	62	60	57	50
Exhaust	55	35	50	52	44	44	40	34	22
210 V / 61 l/s	Total (L <sub>WA</sub> )	63Hz	125Hz	250Hz	500Hz	1kHz	2kHz	4kHz	8kHz
Surrounding	49	32	39	46	39	37	38	35	30
Supply	71	54	58	68	62	61	60	56	49
Exhaust	56	35	50	54	44	43	40	34	24
190 V / 56 l/s	Total (L <sub>WA</sub> )	63Hz	125Hz	250Hz	500Hz	1kHz	2kHz	4kHz	8kHz
Surrounding	47	32	39	42	38	37	38	35	29
Supply	70	54	58	68	62	61	58	55	47
Exhaust	58	35	49	57	43	42	38	33	23
170 V / 54 l/s	Total (L <sub>WA</sub> )	63Hz	125Hz	250Hz	500Hz	1kHz	2kHz	4kHz	8kHz
Surrounding	47	32	39	44	37	36	36	33	29
Supply	70	53	56	69	60	59	56	53	45
Exhaust	62	33	48	61	42	41	37	31	23
150 V / 48 l/s	Total (L <sub>WA</sub> )	63Hz	125Hz	250Hz	500Hz	1kHz	2kHz	4kHz	8kHz
Surrounding	46	30	39	44	35	34	34	31	28
Supply	70	52	54	70	58	57	54	50	42
Exhaust	62	32	46	62	41	39	35	29	22
130 V / 40 l/s	Total (L <sub>WA</sub> )	63Hz	125Hz	250Hz	500Hz	1kHz	2kHz	4kHz	8kHz
Surrounding	45	28	38	43	33	32	30	27	27
Supply	66	51	51	65	55	53	50	46	36
Exhaust	52	30	44	51	39	36	31	26	20
100 V / 25 l/s	Total (L <sub>WA</sub> )	63Hz	125Hz	250Hz	500Hz	1kHz	2kHz	4kHz	8kHz
Surrounding	41	24	39	27	30	28	28	26	26
Supply	56	46	53	45	47	46	40	35	23
Exhaust	41	24	39	27	30	28	28	26	26

# SOUND DATA

## HERU®90 T

230 V / 83 l/s	Total (L <sub>WA</sub> )	63 Hz	125 Hz	250 Hz	500 Hz	1k Hz	2k Hz	4k Hz	8k Hz
Surrounding	50	37	43	47	42	39	36	30	27
Supply	74	60	63	65	67	64	67	64	63
Exhaust	58	47	53	54	49	46	46	41	38
210 V / 81 l/s	Total (L <sub>WA</sub> )	63Hz	125Hz	250Hz	500Hz	1kHz	2kHz	4kHz	8kHz
Surrounding	50	36	42	47	42	39	35	30	27
Supply	73	59	62	65	67	64	66	63	62
Exhaust	58	45	52	53	48	45	46	40	37
190 V / 78 l/s	Total (L <sub>WA</sub> )	63Hz	125Hz	250Hz	500Hz	1kHz	2kHz	4kHz	8kHz
Surrounding	49	34	40	46	41	38	35	29	27
Supply	72	58	61	64	66	64	65	63	61
Exhaust	57	44	51	53	47	45	45	40	37
170 V / 73 l/s	Total (L <sub>WA</sub> )	63Hz	125Hz	250Hz	500Hz	1kHz	2kHz	4kHz	8kHz
Surrounding	48	29	37	46	40	37	33	28	27
Supply	72	57	60	64	65	63	64	62	60
Exhaust	56	44	50	52	46	44	45	39	36
150 V / 68 l/s	Total (L <sub>WA</sub> )	63Hz	125Hz	250Hz	500Hz	1kHz	2kHz	4kHz	8kHz
Surrounding	47	29	35	45	39	36	32	28	26
Supply	70	57	59	62	64	62	62	60	58
Exhaust	55	43	49	50	45	43	43	37	35
130 V / 59 l/s	Total (L <sub>WA</sub> )	63Hz	125Hz	250Hz	500Hz	1kHz	2kHz	4kHz	8kHz
Surrounding	46	28	35	44	37	35	29	27	26
Supply	68	55	58	61	61	60	59	57	54
Exhaust	53	41	49	49	42	42	41	35	34
100 V / 42 l/s	Total (L <sub>WA</sub> )	63Hz	125Hz	250Hz	500Hz	1kHz	2kHz	4kHz	8kHz
Surrounding	42	27	35	40	33	31	26	25	26
Supply	65	54	56	58	58	59	55	53	49
Exhaust	51	39	47	46	39	40	38	31	33

# SOUND DATA

## HERU®90 T EC 2

10 V / 80 l/s	Total (L <sub>WA</sub> )	63 Hz	125 Hz	250 Hz	500 Hz	1k Hz	2k Hz	4k Hz	8k Hz
Surrounding	53	37	40	51	47	41	35	31	29
Supply	63	55	57	57	53	52	50	51	46
Exhaust	60	47	50	56	52	50	46	37	24
9 V / 77 l/s	Total (L <sub>WA</sub> )	63Hz	125Hz	250Hz	500Hz	1kHz	2kHz	4kHz	8kHz
Surrounding	54	37	38	53	46	41	34	31	28
Supply	62	54	56	55	52	51	49	50	44
Exhaust	59	50	50	55	50	49	45	36	23
8 V / 72 l/s	Total (L <sub>WA</sub> )	63Hz	125Hz	250Hz	500Hz	1kHz	2kHz	4kHz	8kHz
Surrounding	53	35	38	51	46	38	33	29	28
Supply	61	54	55	54	50	53	48	48	42
Exhaust	59	52	49	55	50	49	44	35	22
7 V / 68 l/s	Total (L <sub>WA</sub> )	63Hz	125Hz	250Hz	500Hz	1kHz	2kHz	4kHz	8kHz
Surrounding	49	39	39	45	46	38	31	28	27
Supply	59	51	54	53	48	49	46	45	39
Exhaust	64	50	47	63	49	49	42	33	21
6 V / 58 l/s	Total (L <sub>WA</sub> )	63Hz	125Hz	250Hz	500Hz	1kHz	2kHz	4kHz	8kHz
Surrounding	48	31	33	47	38	37	30	27	27
Supply	61	50	52	59	50	44	44	43	37
Exhaust	61	44	44	61	48	46	40	31	20
5 V / 52 l/s	Total (L <sub>WA</sub> )	63Hz	125Hz	250Hz	500Hz	1kHz	2kHz	4kHz	8kHz
Surrounding	48	29	31	47	37	34	28	26	27
Supply	58	49	50	56	48	40	42	40	34
Exhaust	54	42	43	52	45	43	38	29	19
4 V / 45 l/s	Total (L <sub>WA</sub> )	63Hz	125Hz	250Hz	500Hz	1kHz	2kHz	4kHz	8kHz
Surrounding	45	29	30	42	41	32	26	25	26
Supply	52	45	47	46	44	37	37	34	28
Exhaust	51	39	40	47	44	40	35	26	18
3 V / 39 l/s	Total (L <sub>WA</sub> )	63Hz	125Hz	250Hz	500Hz	1kHz	2kHz	4kHz	8kHz
Surrounding	39	25	30	28	35	30	23	25	26
Supply	46	40	41	40	39	32	29	26	22
Exhaust	45	35	36	39	39	37	29	22	18

# SOUND DATA

## HERU®115 T

230 V / 100 l/s	Total (L <sub>WA</sub> )	63 Hz	125 Hz	250 Hz	500 Hz	1k Hz	2k Hz	4k Hz	8k Hz
Surrounding	54	42	51	50	41	40	39	39	32
Supply	77	61	66	72	72	67	65	64	59
Exhaust	59	40	49	57	50	47	43	40	29
210 V / 95 l/s	Total (L <sub>WA</sub> )	63Hz	125Hz	250Hz	500Hz	1kHz	2kHz	4kHz	8kHz
Surrounding	54	41	49	52	40	39	37	36	30
Supply	74	57	64	70	67	65	63	61	54
Exhaust	60	39	49	59	50	47	43	40	29
190 V / 87 l/s	Total (L <sub>WA</sub> )	63Hz	125Hz	250Hz	500Hz	1kHz	2kHz	4kHz	8kHz
Surrounding	52	40	48	49	38	38	36	35	29
Supply	73	56	63	70	66	63	62	60	52
Exhaust	61	38	48	60	49	46	42	38	28
170 V / 81 l/s	Total (L <sub>WA</sub> )	63Hz	125Hz	250Hz	500Hz	1kHz	2kHz	4kHz	8kHz
Surrounding	50	40	47	44	37	38	35	33	28
Supply	73	55	62	70	65	62	61	58	50
Exhaust	61	36	48	60	47	44	40	36	28
150 V / 69 l/s	Total (L <sub>WA</sub> )	63Hz	125Hz	250Hz	500Hz	1kHz	2kHz	4kHz	8kHz
Surrounding	49	40	46	44	36	37	33	32	27
Supply	69	54	59	66	62	58	57	54	44
Exhaust	59	35	45	59	45	42	37	33	27
130 V / 55 l/s	Total (L <sub>WA</sub> )	63Hz	125Hz	250Hz	500Hz	1kHz	2kHz	4kHz	8kHz
Surrounding	47	37	43	44	35	34	30	29	26
Supply	66	52	55	63	59	55	53	49	38
Exhaust	54	33	41	53	42	39	34	30	27
100 V / 36 l/s	Total (L <sub>WA</sub> )	63Hz	125Hz	250Hz	500Hz	1kHz	2kHz	4kHz	8kHz
Surrounding	43	36	42	29	30	33	26	27	26
Supply	56	46	51	49	51	47	43	36	22
Exhaust	42	28	38	37	34	31	26	26	27

# SOUND DATA

## HERU®130 T EC

10 V / 132 l/s	Total (L <sub>WA</sub> )	63 Hz	125 Hz	250 Hz	500 Hz	1k Hz	2k Hz	4k Hz	8k Hz
Surrounding	59	48	46	52	58	43	34	33	29
Supply	80	63	71	76	74	71	67	64	55
Exhaust	63	47	55	60	54	51	46	41	31
8 V / 125 l/s	Total (L <sub>WA</sub> )	63Hz	125Hz	250Hz	500Hz	1kHz	2kHz	4kHz	8kHz
Surrounding	59	47	45	50	58	39	33	32	29
Supply	79	62	69	75	74	70	66	62	53
Exhaust	62	47	54	59	55	50	45	40	30
7 V / 117 l/s	Total (L <sub>WA</sub> )	63Hz	125Hz	250Hz	500Hz	1kHz	2kHz	4kHz	8kHz
Surrounding	55	45	44	49	53	36	31	31	29
Supply	79	61	68	76	72	68	64	60	51
Exhaust	62	46	53	60	52	48	44	39	30
6 V / 110 l/s	Total (L <sub>WA</sub> )	63Hz	125Hz	250Hz	500Hz	1kHz	2kHz	4kHz	8kHz
Surrounding	53	44	42	52	42	34	30	30	29
Supply	77	60	66	75	70	66	62	57	48
Exhaust	66	44	52	66	52	47	42	37	30
5 V / 100 l/s	Total (L <sub>WA</sub> )	63Hz	125Hz	250Hz	500Hz	1kHz	2kHz	4kHz	8kHz
Surrounding	50	43	41	48	38	33	29	29	28
Supply	74	59	63	72	66	63	59	54	45
Exhaust	63	43	49	63	50	45	41	35	29
4 V / 85 l/s	Total (L <sub>WA</sub> )	63Hz	125Hz	250Hz	500Hz	1kHz	2kHz	4kHz	8kHz
Surrounding	46	39	38	44	34	31	27	28	28
Supply	72	58	59	69	65	60	56	51	41
Exhaust	60	41	47	59	46	43	39	33	29
3 V / 65 l/s	Total (L <sub>WA</sub> )	63Hz	125Hz	250Hz	500Hz	1kHz	2kHz	4kHz	8kHz
Surrounding	43	35	38	35	39	30	25	27	28
Supply	64	54	60	55	59	54	49	43	33
Exhaust	52	37	47	48	43	39	35	30	29
2 V / 45 l/s	Total (L <sub>WA</sub> )	63Hz	125Hz	250Hz	500Hz	1kHz	2kHz	4kHz	8kHz
Surrounding	38	30	32	29	31	28	24	27	28
Supply	57	47	52	49	51	46	39	33	29
Exhaust	45	31	41	38	36	35	31	29	29

# SOUND DATA

## HERU®140 T

230 V / 126 l/s	Total (L <sub>WA</sub> )	63 Hz	125 Hz	250 Hz	500 Hz	1k Hz	2k Hz	4k Hz	8k Hz
Surrounding	54	46	49	52	44	41	34	29	26
Supply	77	62	67	69	72	70	67	63	54
Exhaust	64	54	58	60	56	50	41	31	17
210 V / 123 l/s	Total (L <sub>WA</sub> )	63Hz	125Hz	250Hz	500Hz	1kHz	2kHz	4kHz	8kHz
Surrounding	54	46	49	52	43	41	35	30	26
Supply	76	62	66	68	71	69	66	62	53
Exhaust	63	54	57	59	55	49	40	30	16
190 V / 118 l/s	Total (L <sub>WA</sub> )	63Hz	125Hz	250Hz	500Hz	1kHz	2kHz	4kHz	8kHz
Surrounding	55	46	47	54	42	40	34	29	26
Supply	74	62	64	67	70	67	65	59	51
Exhaust	63	53	55	61	53	47	38	28	15
170 V / 110 l/s	Total (L <sub>WA</sub> )	63Hz	125Hz	250Hz	500Hz	1kHz	2kHz	4kHz	8kHz
Surrounding	55	46	46	54	40	39	31	27	26
Supply	73	60	62	66	70	64	62	56	46
Exhaust	61	51	53	60	51	44	36	25	14
150 V / 98 l/s	Total (L <sub>WA</sub> )	63Hz	125Hz	250Hz	500Hz	1kHz	2kHz	4kHz	8kHz
Surrounding	53	42	43	52	38	35	29	26	25
Supply	68	57	58	60	64	59	57	50	40
Exhaust	57	47	50	54	47	40	31	21	12
130 V / 83 l/s	Total (L <sub>WA</sub> )	63Hz	125Hz	250Hz	500Hz	1kHz	2kHz	4kHz	8kHz
Surrounding	44	36	41	38	34	32	28	26	25
Supply	63	53	54	56	58	54	51	42	30
Exhaust	51	42	47	45	42	35	28	16	12
100 V / 58 l/s	Total (L <sub>WA</sub> )	63Hz	125Hz	250Hz	500Hz	1kHz	2kHz	4kHz	8kHz
Surrounding	40	28	37	31	29	30	27	26	25
Supply	54	44	46	48	48	44	38	27	21
Exhaust	45	35	42	38	35	27	18	15	11

## SOUND DATA

### HERU®50 S 2A

230 V / 52 l/s	Total L <sub>WA</sub>	63 Hz	125 Hz	250 Hz	500 Hz	1k Hz	2k Hz	4k Hz	8k Hz
Surrounding	47	36	41	44	38	33	29	27	27
Supply	72	55	59	66	69	65	59	57	47
Exhaust	58	42	55	49	54	46	39	29	20

190 V / 47 l/s	Total L <sub>WA</sub>	63 Hz	125 Hz	250 Hz	500 Hz	1k Hz	2k Hz	4k Hz	8k Hz
Surrounding	45	32	39	42	36	31	28	26	27
Supply	72	54	58	65	70	63	57	55	44
Exhaust	57	42	54	49	53	41	37	27	19

160 V / 43 l/s	Total L <sub>WA</sub>	63 Hz	125 Hz	250 Hz	500 Hz	1k Hz	2k Hz	4k Hz	8k Hz
Surrounding	43	32	39	40	33	29	26	26	27
Supply	68	52	56	63	64	59	54	51	39
Exhaust	55	38	52	47	49	38	34	25	18

130 V / 30 l/s	Total L <sub>WA</sub>	63 Hz	125 Hz	250 Hz	500 Hz	1k Hz	2k Hz	4k Hz	8k Hz
Surrounding	41	26	37	37	30	26	24	26	27
Supply	65	49	54	60	61	53	48	44	31
Exhaust	53	33	51	42	45	33	30	22	17

100 V / 17 l/s	Total L <sub>WA</sub>	63 Hz	125 Hz	250 Hz	500 Hz	1k Hz	2k Hz	4k Hz	8k Hz
Surrounding	38	25	36	29	28	24	24	25	27
Supply	61	44	50	50	60	46	39	34	22
Exhaust	52	30	51	36	45	30	27	21	16

### HERU®75 S 2A

230 V / 65 l/s	Total L <sub>WA</sub>	63 Hz	125 Hz	250 Hz	500 Hz	1k Hz	2k Hz	4k Hz	8k Hz
Surrounding	51	34	44	48	46	37	35	32	28
Supply	76	57	63	68	72	68	66	61	50
Exhaust	62	46	57	55	57	46	41	30	20

190 V / 62 l/s	Total L <sub>WA</sub>	63 Hz	125 Hz	250 Hz	500 Hz	1k Hz	2k Hz	4k Hz	8k Hz
Surrounding	50	33	42	47	45	36	33	30	26
Supply	74	58	65	68	70	66	62	59	47
Exhaust	61	48	57	56	56	45	38	28	17

160 V / 53 l/s	Total L <sub>WA</sub>	63 Hz	125 Hz	250 Hz	500 Hz	1k Hz	2k Hz	4k Hz	8k Hz
Surrounding	48	32	42	44	40	32	30	27	26
Supply	72	57	63	66	67	63	59	56	43
Exhaust	60	46	57	55	53	42	35	25	13

130 V / 36 l/s	Total L <sub>WA</sub>	63 Hz	125 Hz	250 Hz	500 Hz	1k Hz	2k Hz	4k Hz	8k Hz
Surrounding	46	31	41	44	36	29	27	26	26
Supply	70	56	62	65	64	60	55	52	39
Exhaust	59	48	56	53	53	39	32	22	12

100 V / 21 l/s	Total L <sub>WA</sub>	63 Hz	125 Hz	250 Hz	500 Hz	1k Hz	2k Hz	4k Hz	8k Hz
Surrounding	40	32	36	37	30	25	23	24	26
Supply	62	53	58	57	55	51	46	40	24
Exhaust	53	43	51	45	42	31	24	12	7

# SOUND DATA

## HERU®90 S EC 2A

10 V / 87 l/s	Total (L <sub>WA</sub> )	63 Hz	125 Hz	250 Hz	500 Hz	1k Hz	2k Hz	4k Hz	8k Hz
Surrounding	52	41	41	43	50	40	37	32	29
Supply	83	60	64	68	83	73	68	65	57
Exhaust	69	46	55	56	68	53	46	37	29
9 V / 84 l/s	Total (L <sub>WA</sub> )	63Hz	125Hz	250Hz	500Hz	1kHz	2kHz	4kHz	8kHz
Surrounding	50	40	41	42	48	40	36	31	28
Supply	81	60	64	69	80	71	67	64	56
Exhaust	68	45	54	57	68	52	45	37	28
8 V / 78 l/s	Total (L <sub>WA</sub> )	63Hz	125Hz	250Hz	500Hz	1kHz	2kHz	4kHz	8kHz
Surrounding									
Supply	76	60	62	71	72	68	65	62	54
Exhaust	65	45	53	62	59	50	44	35	28
7 V / 71 l/s	Total (L <sub>WA</sub> )	63Hz	125Hz	250Hz	500Hz	1kHz	2kHz	4kHz	8kHz
Surrounding	49	39	38	45	44	37	33	29	28
Supply	73	60	61	68	69	65	63	60	51
Exhaust	60	46	51	56	54	48	42	33	27
6 V / 65 l/s	Total (L <sub>WA</sub> )	63Hz	125Hz	250Hz	500Hz	1kHz	2kHz	4kHz	8kHz
Surrounding	47	37	38	45	40	35	31	29	28
Supply	71	55	59	67	65	63	60	57	48
Exhaust	57	42	50	52	52	46	40	32	27
5 V / 58 l/s	Total (L <sub>WA</sub> )	63Hz	125Hz	250Hz	500Hz	1kHz	2kHz	4kHz	8kHz
Surrounding	43	36	36	39	35	36	30	28	28
Supply	72	53	57	69	65	61	57	54	44
Exhaust	56	40	49	52	50	44	38	30	27
4 V / 46 l/s	Total (L <sub>WA</sub> )	63Hz	125Hz	250Hz	500Hz	1kHz	2kHz	4kHz	8kHz
Surrounding	43	33	35	40	38	33	28	27	28
Supply	67	50	52	66	58	54	51	48	38
Exhaust	57	38	46	56	47	40	33	27	27
3 V / 31 l/s	Total (L <sub>WA</sub> )	63Hz	125Hz	250Hz	500Hz	1kHz	2kHz	4kHz	8kHz
Surrounding	39	30	34	28	31	30	27	28	28
Supply	56	46	50	49	51	47	44	37	30
Exhaust	47	32	43	39	41	34	28	26	27



# SOUND DATA

## HERU®130 S 2A

230 V / 119 l/s	Total L <sub>WA</sub>	63 Hz	125 Hz	250 Hz	500 Hz	1k Hz	2k Hz	4k Hz	8k Hz
Surrounding	49	33	40	45	42	37	35	30	26
Supply	77	62	67	69	72	70	67	63	54
Exhaust	64	54	58	60	56	50	41	31	17

210 V / 113 l/s	Total L <sub>WA</sub>	63 Hz	125 Hz	250 Hz	500 Hz	1k Hz	2k Hz	4k Hz	8k Hz
Surrounding	49	34	41	46	43	38	35	31	26
Supply	76	62	66	68	71	69	66	62	53
Exhaust	63	54	57	59	55	49	40	30	16

190 V / 104 l/s	Total L <sub>WA</sub>	63 Hz	125 Hz	250 Hz	500 Hz	1k Hz	2k Hz	4k Hz	8k Hz
Surrounding	49	33	41	46	42	36	34	30	26
Supply	74	62	64	67	70	67	65	59	51
Exhaust	63	53	55	61	53	47	38	28	15

170 V / 91 l/s	Total L <sub>WA</sub>	63 Hz	125 Hz	250 Hz	500 Hz	1k Hz	2k Hz	4k Hz	8k Hz
Surrounding	47	31	39	44	40	34	31	28	26
Supply	73	60	62	66	70	64	62	56	46
Exhaust	61	51	53	60	51	44	36	25	14

150 V / 73 l/s	Total L <sub>WA</sub>	63 Hz	125 Hz	250 Hz	500 Hz	1k Hz	2k Hz	4k Hz	8k Hz
Surrounding	43	29	38	39	36	31	28	26	25
Supply	68	57	58	60	64	59	57	50	40
Exhaust	57	47	50	54	47	40	31	21	12

130 V / 54 l/s	Total L <sub>WA</sub>	63 Hz	125 Hz	250 Hz	500 Hz	1k Hz	2k Hz	4k Hz	8k Hz
Surrounding	40	26	37	33	31	29	25	25	25
Supply	63	53	54	56	58	54	51	42	30
Exhaust	51	42	47	45	42	35	28	16	12

100 V / 31 l/s	Total L <sub>WA</sub>	63 Hz	125 Hz	250 Hz	500 Hz	1k Hz	2k Hz	4k Hz	8k Hz
Surrounding	39	23	38	27	27	27	23	25	25
Supply	54	44	46	48	48	44	38	27	21
Exhaust	45	35	42	38	35	27	18	15	11

# SOUND DATA

## HERU®130 S EC 2A

10 V / 137 l/s	Total (L <sub>WA</sub> )	63 Hz	125 Hz	250 Hz	500 Hz	1k Hz	2k Hz	4k Hz	8k Hz
Surrounding	55	44	47	49	51	47	38	31	29
Supply	80	63	68	77	73	71	67	64	56
Exhaust	68	54	61	63	64	53	44	34	29
8 V / 130 l/s	Total (L <sub>WA</sub> )	63Hz	125Hz	250Hz	500Hz	1kHz	2kHz	4kHz	8kHz
Surrounding	54	43	45	51	50	39	37	30	28
Supply	79	62	67	76	71	69	65	62	54
Exhaust	67	54	61	63	60	51	43	33	28
7 V / 120 l/s	Total (L <sub>WA</sub> )	63Hz	125Hz	250Hz	500Hz	1kHz	2kHz	4kHz	8kHz
Surrounding	51	42	43	47	46	38	36	29	29
Supply	76	62	65	73	70	68	64	60	52
Exhaust	69	52	59	68	58	50	42	32	28
6 V / 110 l/s	Total (L <sub>WA</sub> )	63Hz	125Hz	250Hz	500Hz	1kHz	2kHz	4kHz	8kHz
Surrounding	51	41	42	47	46	37	34	29	28
Supply	75	61	63	71	68	66	62	58	50
Exhaust	67	50	58	66	57	48	40	31	28
5 V / 100 l/s	Total (L <sub>WA</sub> )	63Hz	125Hz	250Hz	500Hz	1kHz	2kHz	4kHz	8kHz
Surrounding	48	39	40	45	38	35	32	28	28
Supply	73	60	62	70	66	63	60	56	47
Exhaust	66	48	56	66	54	47	38	29	28
4 V / 85 l/s	Total (L <sub>WA</sub> )	63Hz	125Hz	250Hz	500Hz	1kHz	2kHz	4kHz	8kHz
Surrounding	46	36	38	43	35	36	30	27	28
Supply	72	59	60	69	65	60	56	52	43
Exhaust	63	46	54	62	52	44	36	29	28
3 V / 65 l/s	Total (L <sub>WA</sub> )	63Hz	125Hz	250Hz	500Hz	1kHz	2kHz	4kHz	8kHz
Surrounding	41	31	35	30	38	34	27	27	28
Supply	64	56	58	55	58	55	50	44	35
Exhaust	54	42	49	48	48	41	32	28	28
2 V / 45 l/s	Total (L <sub>WA</sub> )	63Hz	125Hz	250Hz	500Hz	1kHz	2kHz	4kHz	8kHz
Surrounding	39	27	36	25	30	33	25	27	28
Supply	58	48	53	49	52	48	41	35	29
Exhaust	50	36	46	43	43	38	28	28	28

# SOUND DATA

## HERU®180 S 2A

230 V / 185 l/s	Total L <sub>WA</sub>	63 Hz	125 Hz	250 Hz	500 Hz	1k Hz	2k Hz	4k Hz	8k Hz
Surrounding	50	43	44	44	44	39	38	35	31
Supply	77	53	60	64	75	70	68	63	57
Exhaust	59	48	53	54	52	45	37	34	27

190 V / 181 l/s	Total L <sub>WA</sub>	63 Hz	125 Hz	250 Hz	500 Hz	1k Hz	2k Hz	4k Hz	8k Hz
Surrounding	48	41	44	43	42	37	33	31	30
Supply	75	51	59	63	71	68	67	61	55
Exhaust	56	46	50	50	51	41	36	32	25

170 V / 152 l/s	Total L <sub>WA</sub>	63 Hz	125 Hz	250 Hz	500 Hz	1k Hz	2k Hz	4k Hz	8k Hz
Surrounding	47	40	43	41	40	35	31	30	30
Supply	71	50	58	61	66	66	64	58	51
Exhaust	55	44	49	48	51	39	34	30	24

150 V / 116 l/s	Total L <sub>WA</sub>	63 Hz	125 Hz	250 Hz	500 Hz	1k Hz	2k Hz	4k Hz	8k Hz
Surrounding	45	39	42	40	34	31	28	29	29
Supply	67	51	54	60	61	60	60	54	47
Exhaust	52	44	47	49	42	36	31	28	24

## HERU®180 S EC 2A

10 V / 160 l/s	Total (L <sub>WA</sub> )	63 Hz	125 Hz	250 Hz	500 Hz	1k Hz	2k Hz	4k Hz	8k Hz
Surrounding	58	49	50	53	53	50	38	33	29
Supply	78	59	62	73	72	71	70	63	52
Exhaust	65	52	55	63	58	49	45	36	33

8 V / 150 l/s	Total (L <sub>WA</sub> )	63Hz	125Hz	250Hz	500Hz	1kHz	2kHz	4kHz	8kHz
Surrounding	54	48	49	50	46	41	37	32	29
Supply	76	59	61	71	71	69	68	61	49
Exhaust	63	51	54	60	55	46	43	35	33

7 V / 145 l/s	Total (L <sub>WA</sub> )	63Hz	125Hz	250Hz	500Hz	1kHz	2kHz	4kHz	8kHz
Surrounding	52	48	47	48	44	39	35	31	28
Supply	74	58	60	67	69	68	66	59	47
Exhaust	61	50	53	58	53	45	42	34	33

6 V / 130 l/s	Total (L <sub>WA</sub> )	63Hz	125Hz	250Hz	500Hz	1kHz	2kHz	4kHz	8kHz
Surrounding	51	47	45	47	44	38	33	30	28
Supply	73	57	58	68	67	66	64	56	44
Exhaust	59	49	51	57	51	43	40	33	33

5 V / 120 l/s	Total (L <sub>WA</sub> )	63Hz	125Hz	250Hz	500Hz	1kHz	2kHz	4kHz	8kHz
Surrounding	49	45	43	46	40	36	31	29	27
Supply	71	56	56	67	65	63	62	53	41
Exhaust	59	47	50	57	49	41	38	32	33

4 V / 105 l/s	Total (L <sub>WA</sub> )	63Hz	125Hz	250Hz	500Hz	1kHz	2kHz	4kHz	8kHz
Surrounding	47	45	43	43	39	34	30	28	27
Supply	69	54	55	66	62	60	58	49	38
Exhaust	57	45	48	56	46	39	36	32	33

3 V / 80 l/s	Total (L <sub>WA</sub> )	63Hz	125Hz	250Hz	500Hz	1kHz	2kHz	4kHz	8kHz
Surrounding	44	42	41	35	37	34	26	27	27
Supply	62	50	55	54	55	55	51	41	34
Exhaust	51	40	47	45	42	35	32	32	33

2 V / 60 l/s	Total (L <sub>WA</sub> )	63Hz	125Hz	250Hz	500Hz	1kHz	2kHz	4kHz	8kHz
Surrounding	39	33	36	27	31	32	26	27	27
Supply	54	44	47	46	48	47	39	33	33
Exhaust	45	36	40	38	37	32	30	31	33

# PRESSURE/FLOW DIAGRAM

## HERU®62 T

### PRESSURE/FLOW SUPPLY

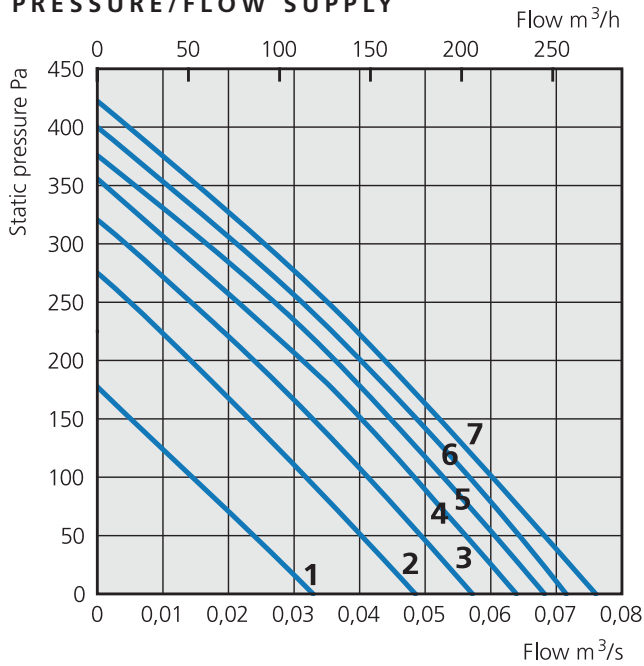

## HERU®90 T

### PRESSURE/FLOW SUPPLY

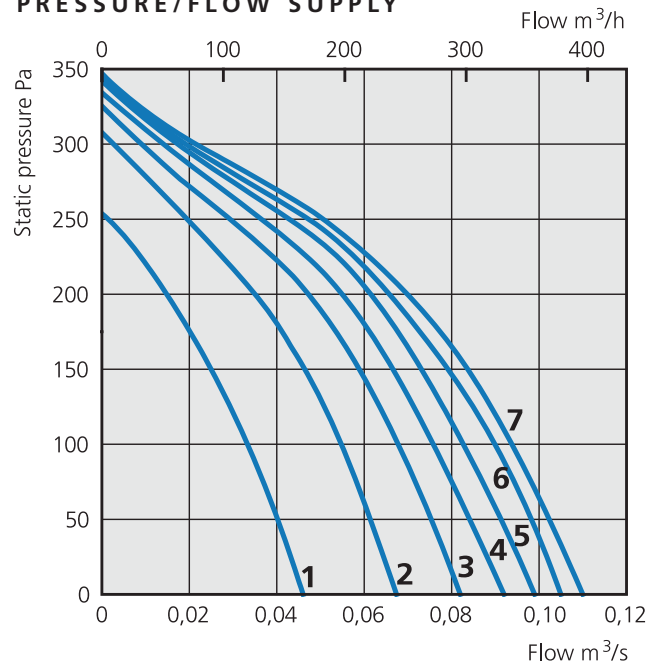

### PRESSURE/FLOW EXHAUST

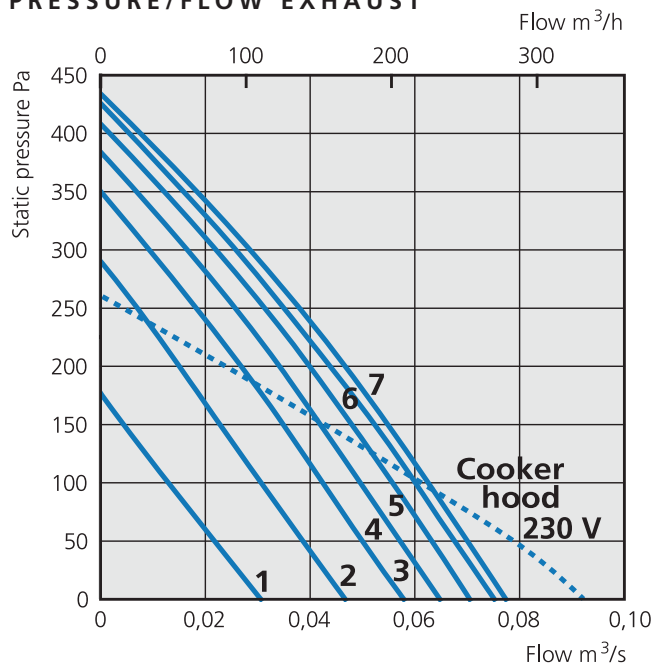

### PRESSURE/FLOW EXHAUST

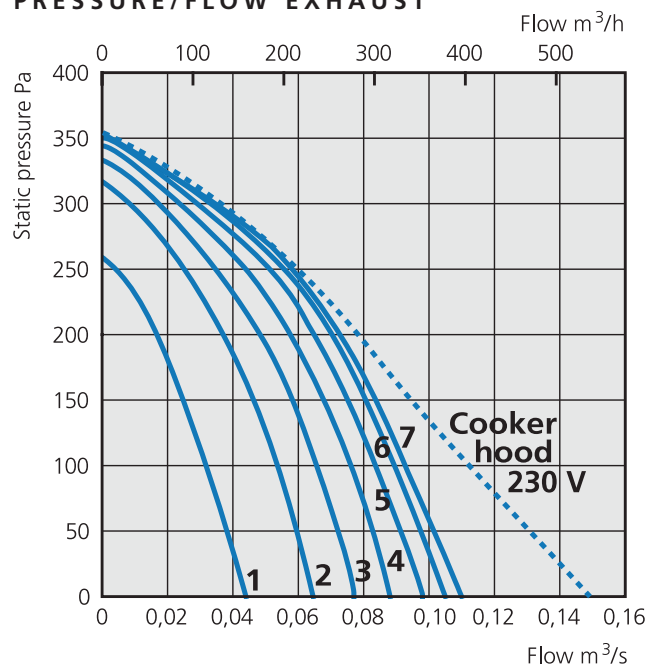

### FAN POWER/FLOW

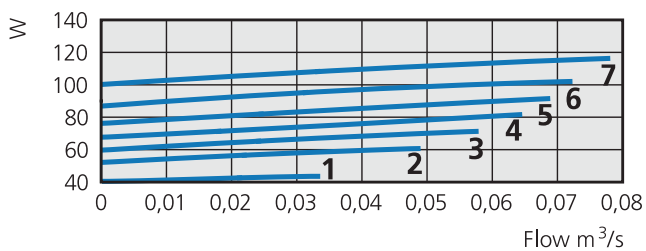

### FAN POWER/FLOW

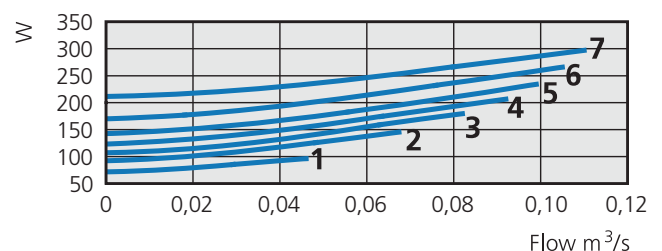

### TRANSFORMER STEP

1	2	3	4	5	6	7
100V	130V	150V	170V	190V	210V	230V

### TRANSFORMER STEP

1	2	3	4	5	6	7
100V	130V	150V	170V	190V	210V	230V

# PRESSURE/FLOW DIAGRAM

The pressure/flow diagrams applies to both supply and exhaust air.  
Indicated power and SFP applies to both fans together.

**HERU®90 T EC 2**  
**PRESSURE/FLOW**

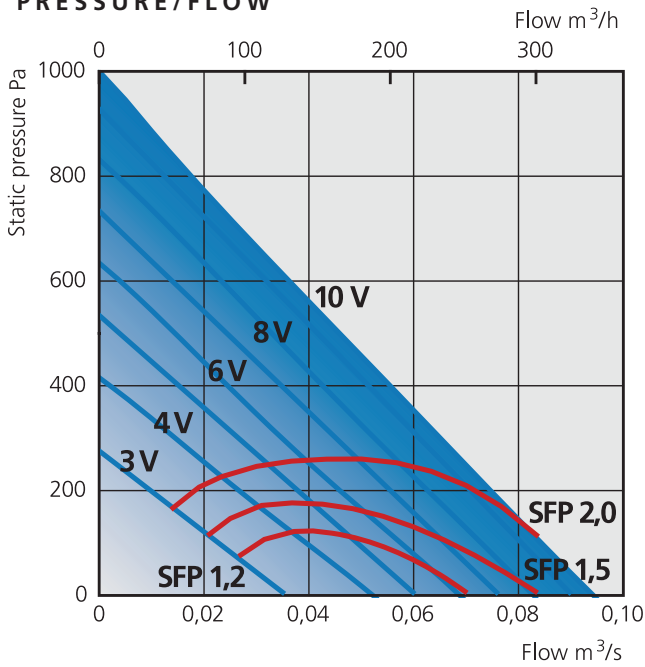

**HERU®130 T EC**  
**PRESSURE/FLOW**

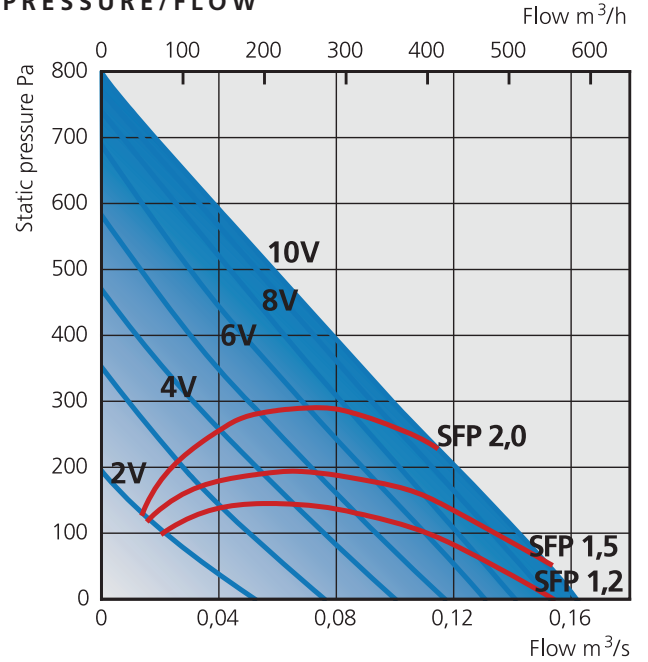

**FAN POWER/FLOW**

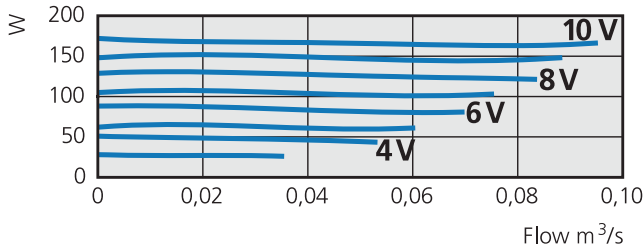

**FAN POWER/FLOW**

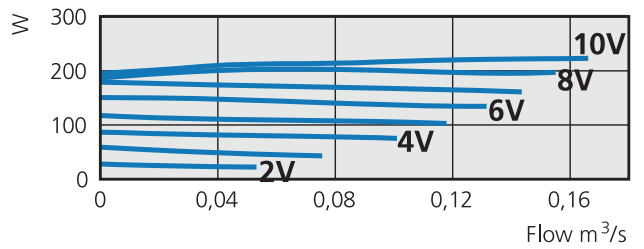

# PRESSURE/FLOW DIAGRAM

## HERU®115 T

### PRESSURE/FLOW SUPPLY

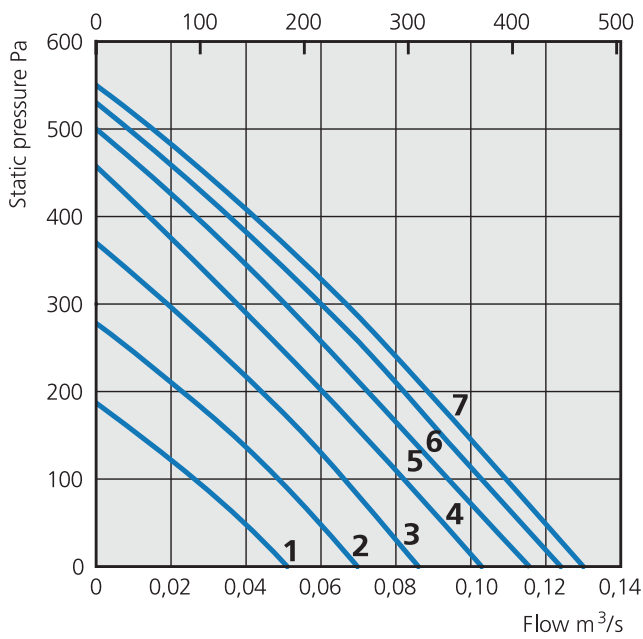

## HERU®140 T

### PRESSURE/FLOW SUPPLY

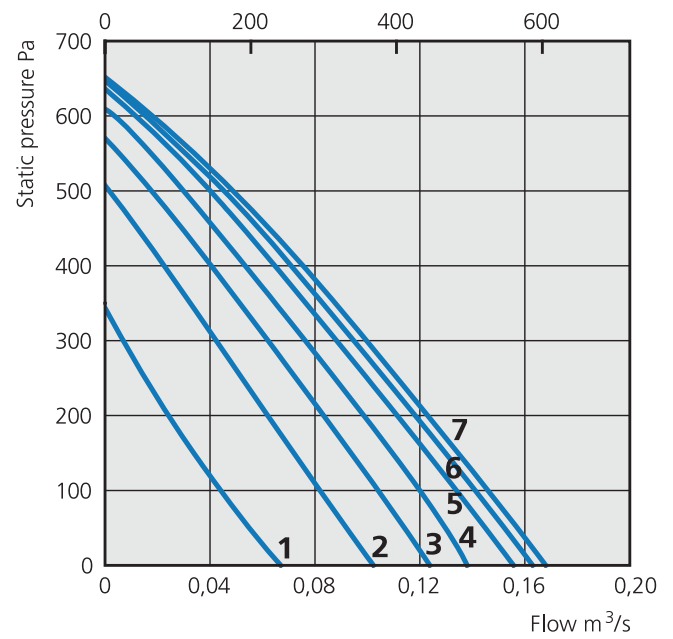

### PRESSURE/FLOW EXHAUST

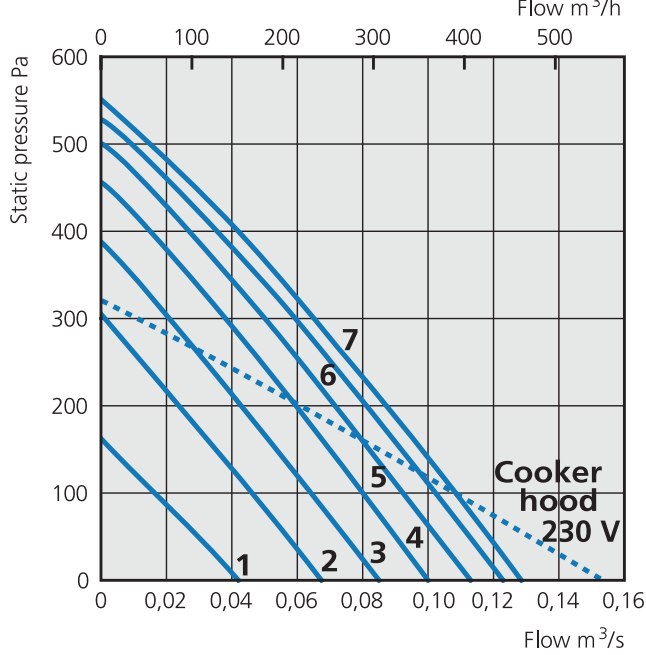

### PRESSURE/FLOW EXHAUST

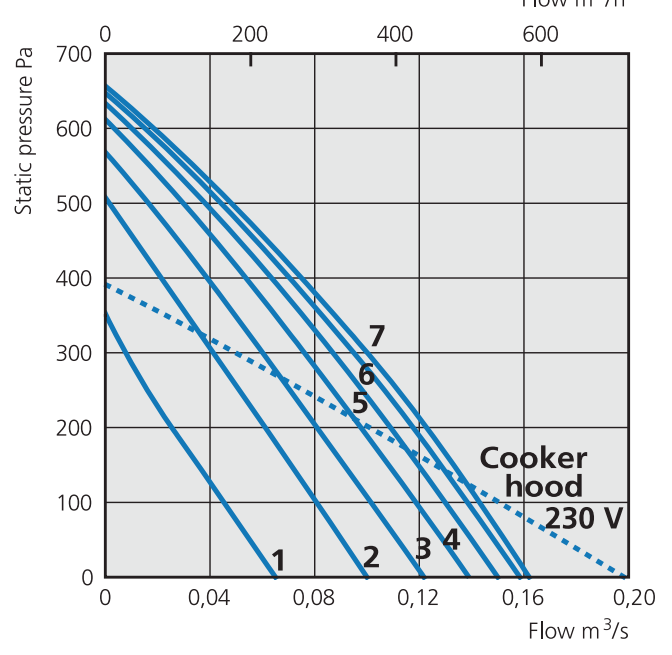

### FAN POWER/FLOW

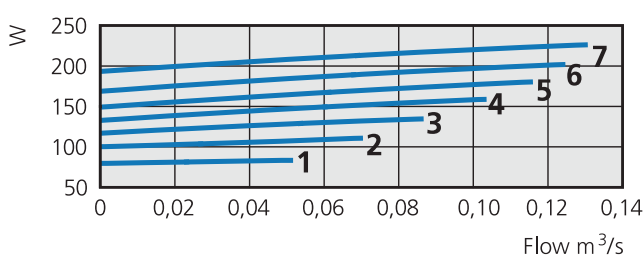

### FAN POWER/FLOW

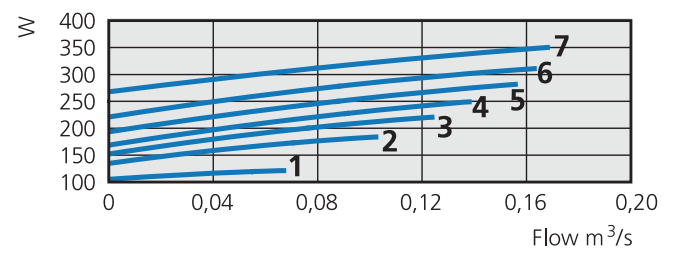

### TRANSFORMER STEP

1	2	3	4	5	6	7
100V	130V	150V	170V	190V	210V	230V

### TRANSFORMER STEP

1	2	3	4	5	6	7
100V	130V	150V	170V	190V	210V	230V

# PRESSURE/FLOW DIAGRAM

## HERU®50 S 2A

### PRESSURE/FLOW

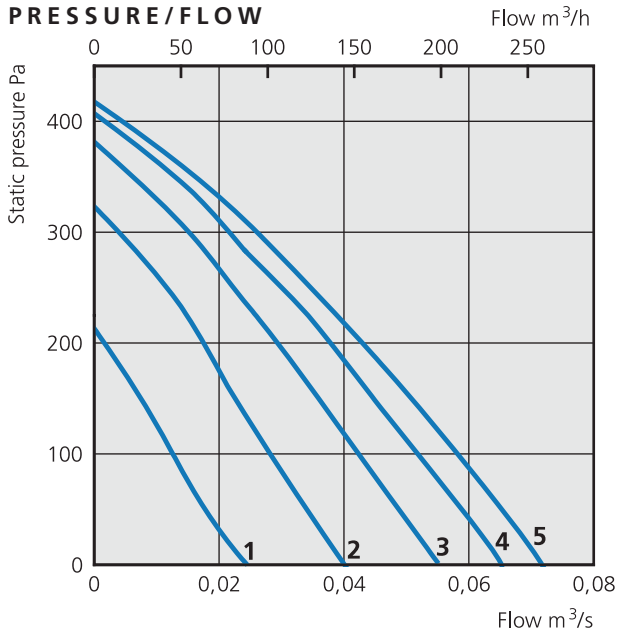

## HERU®75 S 2A

### PRESSURE/FLOW

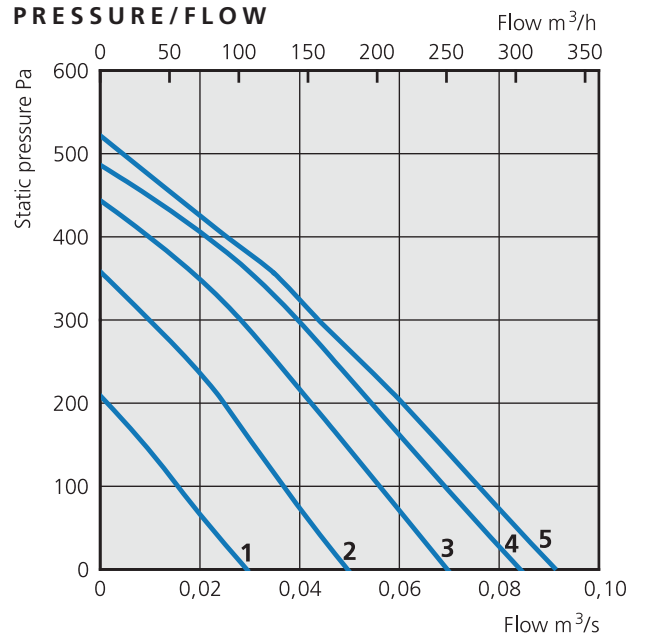

### FAN POWER/FLOW

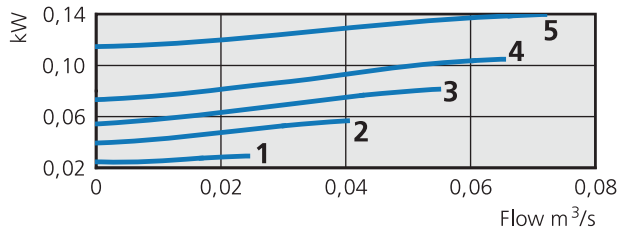

### FAN POWER/FLOW

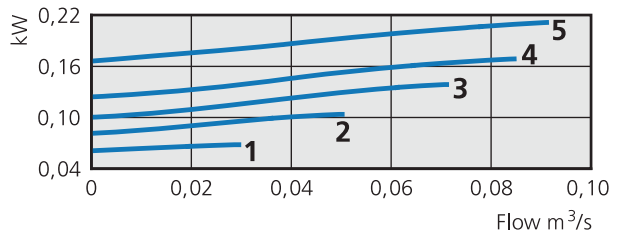

1 = 100 V. 2 = 130 V. 3 = 160 V. 4 = 190 V. 5 = 230 V.

## HERU®90 S EC 2A

### PRESSURE/FLOW

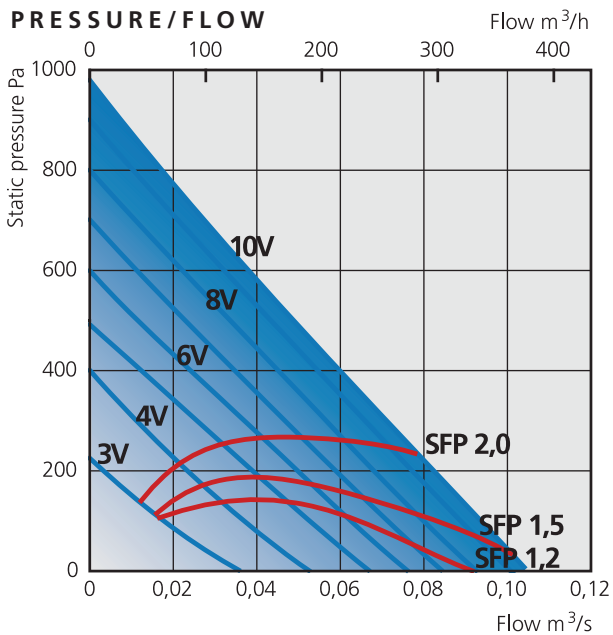

### FAN POWER/FLOW

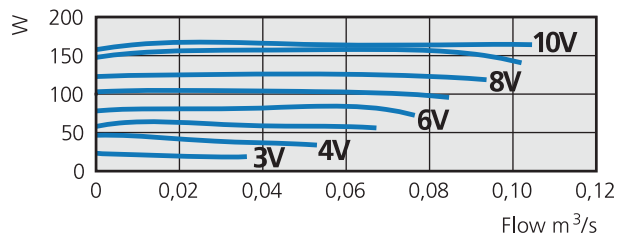

# PRESSURE/FLOW DIAGRAM

## HERU®130 S 2A

### PRESSURE/FLOW

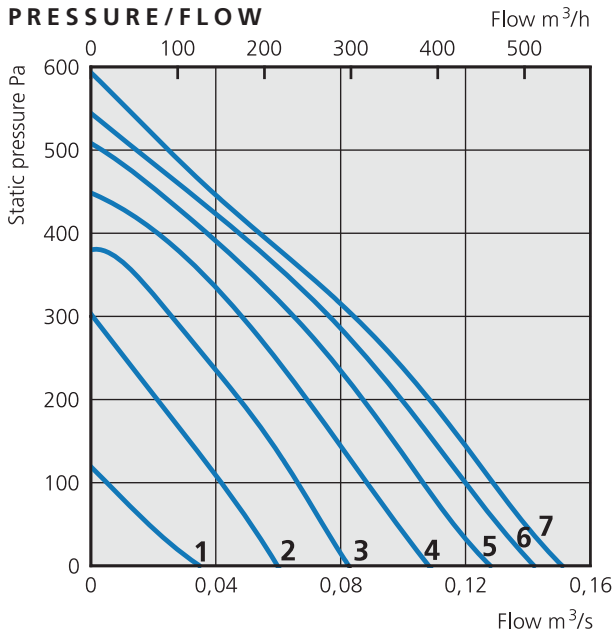

### FAN POWER/FLOW

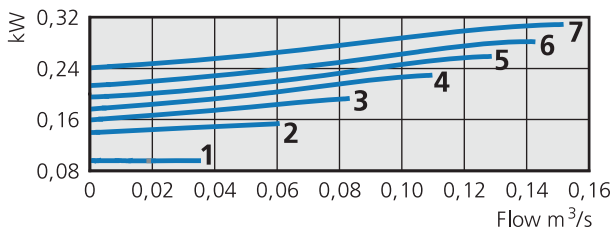

1 = 100 V. 2 = 130 V. 3 = 150 V. 4 = 170 V. 5 = 190 V. 6 = 210 V. 7 = 230 V.

## HERU®180 S 2A

### PRESSURE/FLOW

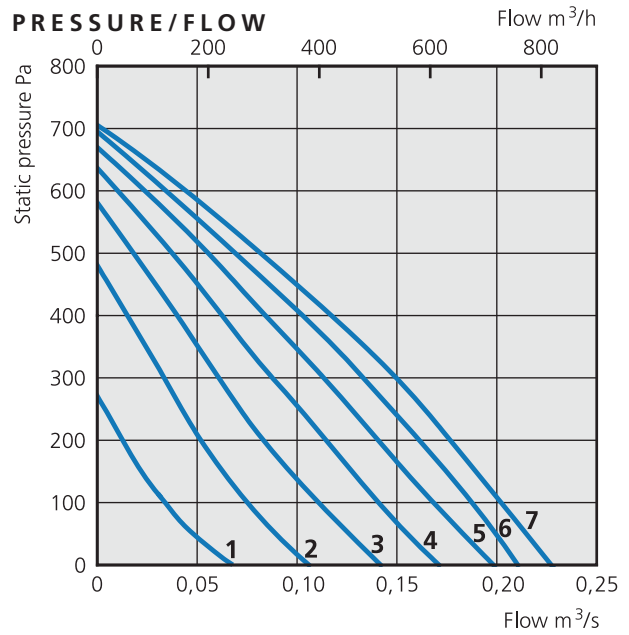

### FAN POWER/FLOW

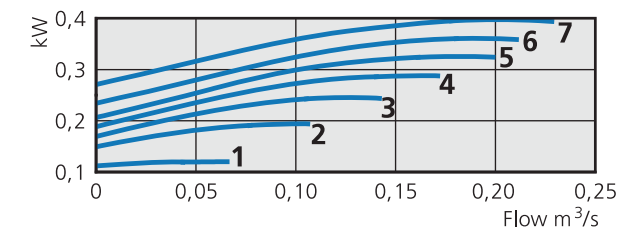

## HERU®130 S EC 2A

### PRESSURE/FLOW

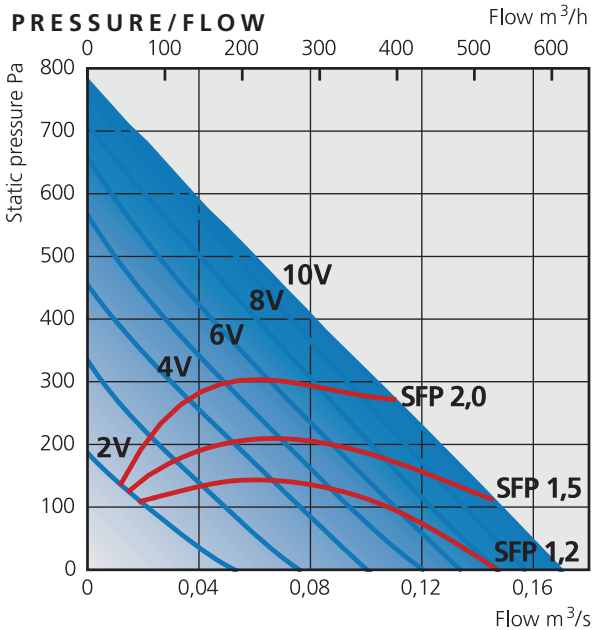

### FAN POWER/FLOW

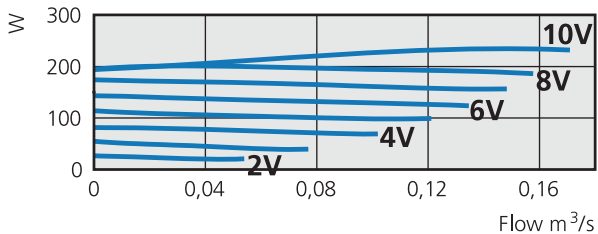

## HERU®180 S EC 2A

### PRESSURE/FLOW

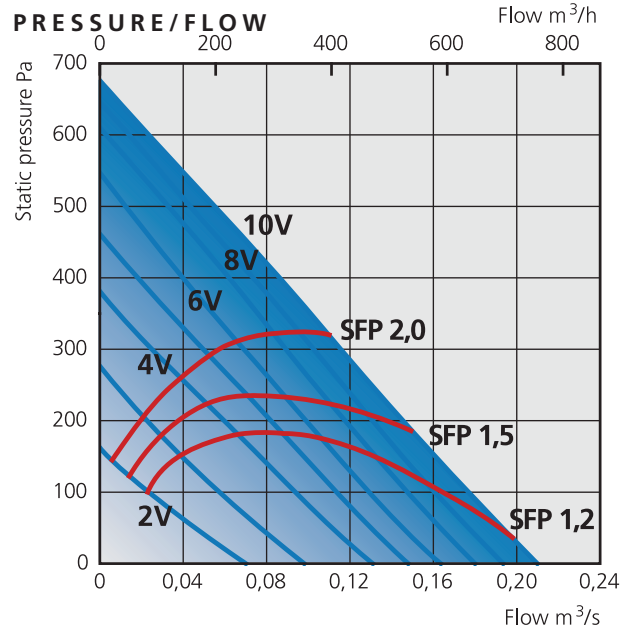

### FAN POWER/FLOW

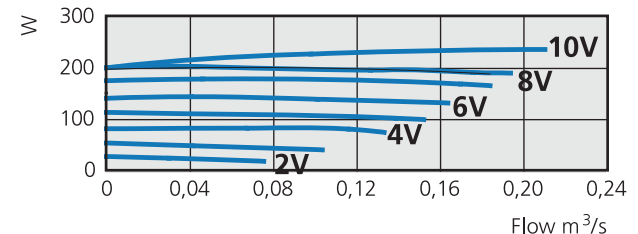



## CLEANING/FILTER CHANGE

- Always disconnect the power and make sure that it can not be connected.
- Open the lid by removing the two screws (screw-driver PH2).
- Filter change should be done regularly. We recommend at least once a year. The filters should not be cleaned with compressed air or vacuum cleaner. The filters are taken out by pulling them straight out from their fastening strips **1**. When changing filter also check if the fans are dirty.
- The fans are taken out after the electrical socket has been disconnected **2** and loosen the screw. **3** Than just pull out the fan straight out from the unit. **4**

Dismount the motor plate from the fan housing (the outer screws) and lift out the motor with the fan wheel. If necessary the fan wheel and fan housing are wiped clean with a damp cloth. The interior of the unit housing can be wiped when necessary.

- Cleaning the rotor: Remove the rotor motor by lift of the belt **5** from the rotor motor, disconnect the quick connection and remove the ground cable **6**. Pull out the motor **7**. For Heru 130 T EC, loosen the rotor motor grippers. Pull out the pegs **8** and pulled/budged out the rotor **9**. Clean the rotor gentle with compressed air or running water.

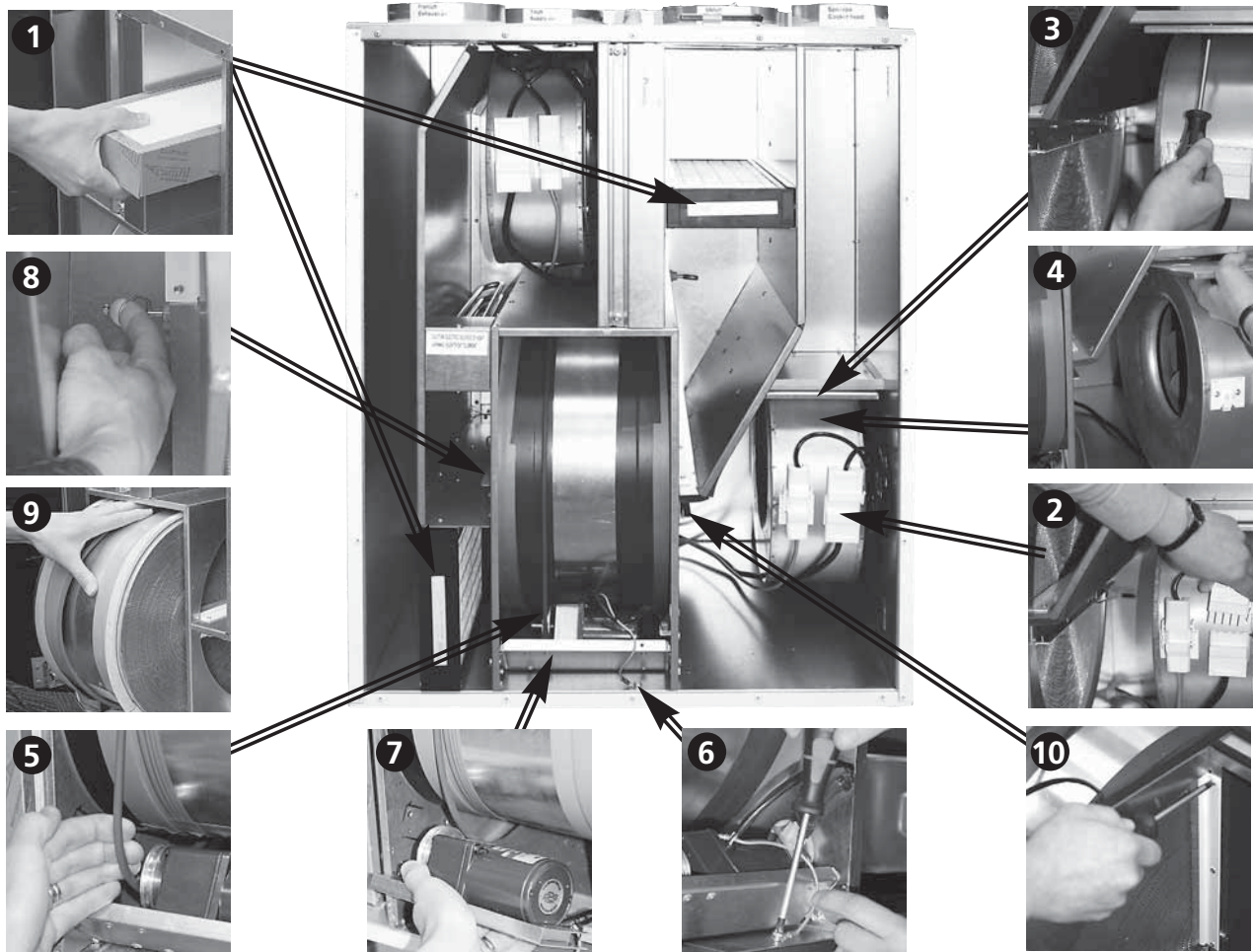

## BELT/TIGHTENING MATERIAL CHANGE

### EQUIPMENT

- Screwdriver PH1, PH2. Service set 6000102.

### DISMOUNTING

1. Pull out filter **1**.
2. Remove the tape that keeps the rotor tightening in place, 2 pieces, and move them in towards the centre of the rotor.
3. Lift off belt **5** from the rotor motor, disconnect the electrical socket and loosen the ground cable **6**.
4. Pull out the rotor motor **7**.
5. Pull out the pegs **8** and pull out the rotor.
6. Dismount brush seals **10**, 2 long and 2 short pieces with a PH1 screwdriver.

### MOUNTING

1. Change the rotor tightening material and belt on the rotor.
2. Mount the brush seals.
3. Lift the rotor into the box. See to the pegs ports in the right position.
4. Push out the rotor tightening material over the edge onto the middle wall. Mount a new tape.
5. Mount the rotor motor grippers, Heru 130 T EC.
6. Push in the rotor motor and lift the belt onto the belt plate.
7. Mount filters.
8. Mount the electrical socket. Check the function of the fans and rotor before closing the lid.

## CLEANING/FILTER CHANGE

- The filters should be changed once a year or at alarm for filter change. At alarm for Filter Change, this should be done as soon as possible; as there otherwise is a risk that the adjusted flow is not obtained.
- Always turn off the electrical supply and ensure that it cannot be turned on.
- Open the lid by removing the four screws **15** in every corner.
- The filters are taken out by pulling them straight out from their fastening strips **4**.
- When changing a filter it is also appropriate to check if the fans are dirty.
- The fans are taken out, after the quick connection has been disconnected **1**, removing the screw **2** and pulling it straight out from the unit **3**. Dismount the motor plate from the fan house **12** (the outer screws) and lift out the motor with the fan wheel. If necessary the fan wheel and fan housing are wiped clean with a damp cloth. The interior of the unit housing can be wiped when necessary.
- If necessary the rotor **6** can also be dismantled (see Dismounting).

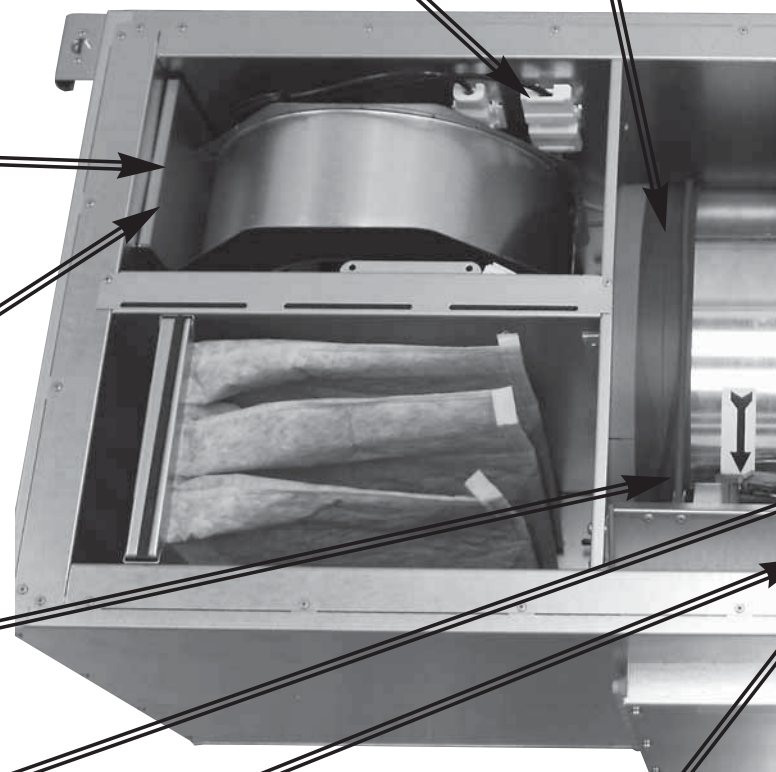
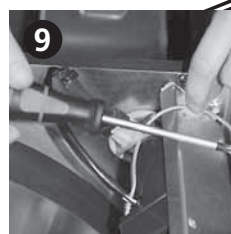
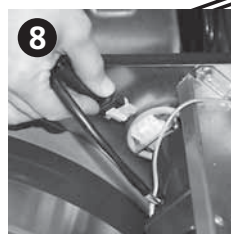
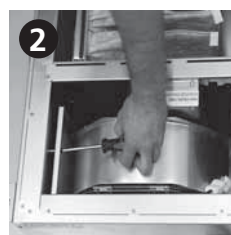

## BELT/TIGHTENING MATERIAL CHANGE EQUIPMENT

- Screwdriver TX20 or screwdriver 1x5 (0,8x4)
- Screwdriver PH 1
- 2 Allen keys 6 mm (preferably with round head)
- Service kit 6000102 for HERU®90 S EC,  
Service kit 6000188 for HERU®130 S EC  
or 6000189 for HERU®180 S EC

## DISMOUNTING

1. Loosen electrical socket **1** and screw **2** and carefully pull out fans **3**.
2. Pull out the filters **4**.
3. Dismount sealing joints **5** both sides of the rotor **5**, 2 long and 2 short pieces with a PH1 screwdriver.
4. Remove the tape that keeps the rotor tightening material **6**, 2 pieces in place and move them in towards the centre of the rotor **6**.
5. Lift off belt **7** from the rotor motor **8**, disconnect the electrical socket **8** and loosen the ground cable **9**.
6. Pull out the rotor motor from the grippers **10** and than dismount them **11**.
7. For HERU®130/180 S EC loosen electrical socket with bracket **12** with screwdriver TX20 and hang it over the edge towards the fan.
8. Dismount the Allen screws **13**, 2 pieces that hold the rotor. Lift out the rotor **14**.

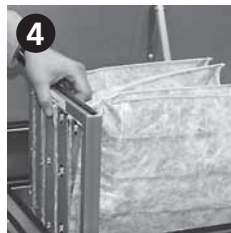
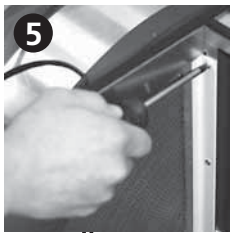

Change the rotor tightenings and the rotor belt.

## MOUNTING

1. Lift the rotor into the box using the new belt.
2. Mount with Allen screws, distancers and tightenings.
3. Push out the rotor tightening material over the edge onto the middle wall. Mount a new tape.
4. Push in the rotor motor in the grippers and lift the rotor belt onto the belt plate.
5. Mount electrical socket with bracket.
6. Mount the brush seals.
7. Mount filters and fans (carefully so there's no damage to the seal trim).
8. Mount the electrical sockets. Check the function of the fans and rotor before closing the lid.



## SKIFTE AV ELEKTRISK EFTERVÄRMARE HERU®S

Heru S is when delivered equipped with an electrical heater which is mounted and connected for **right handing application**.

If there is **left handing application need**, the electrical heater has to be moved according to following direction:

1. Disconnect the quick connection **1**.
2. Dismantle the heater by unscrewing the two screws **2**.
3. Budge out the heater from the brackets on the bottom of the unit and lift the heater **3**.
4. Move the heater to corresponding side **4**.
5. Make sure the bar at the bottom goes in the bracket properly. Screw tight the heater **2**. Connected the quick connection **1**.
6. Connect the heater for left handing application according to wiring diagram **5**.
7. Adjust the change in "Service Menu" and submenu "Flow direction". See page 104.

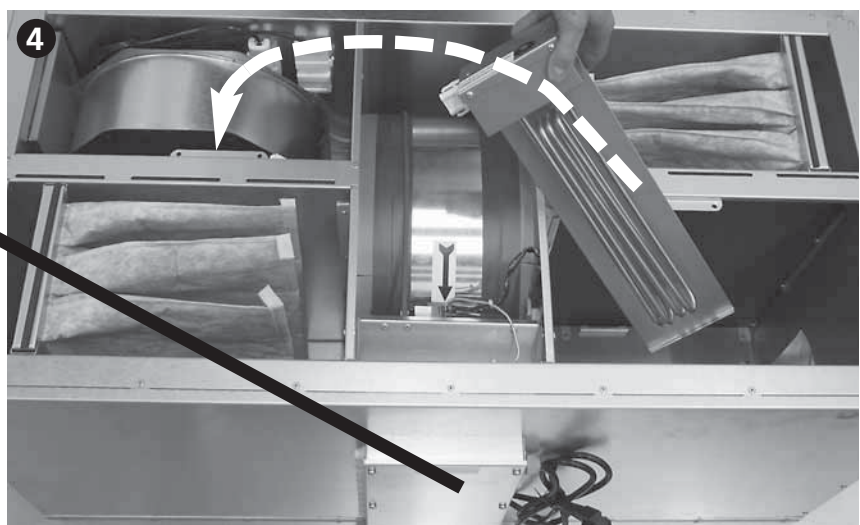
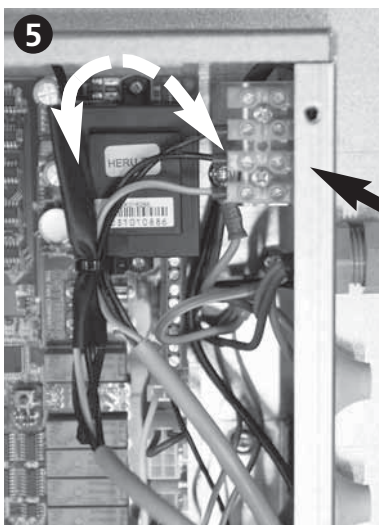
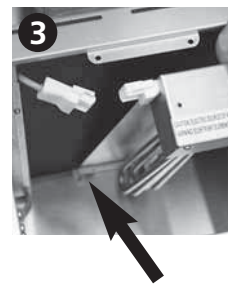
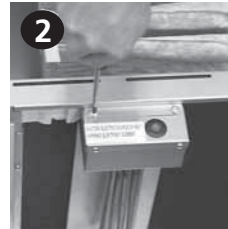

## ACCESSORIES

Duct sensor (GT8 och GT7) . . . . .	.4020286
Room sensor (GT8) . . . . .	.4020310
CO2 Room sensor . . . . .	.4020302
RH Room sensor . . . . .	.4020301
Freeze protection sensor (GT5) . . . . .	.4020309
Pressure sensor . . . . .	.9500111
Extension cord for antenna . . . . .	.6010011
Damper motor with pull back string . . . . .	.1220488
Relay pump control . . . . .	.6000195
Electric duct heater 5,0 kW Ø250 incl. clamping device to HERU®180 S EC . . . . .	.6000193
Heating coil, 5 kW incl. 2-way valve and valve motor, HERU®115 T/130 T EC/140 T . . . . .	.8010064
Heating coil, 5 kW incl. 3-way valve and valve motor, HERU®115 T/130 T EC/140 T . . . . .	.8010065
Heating coil, 5 kW incl. 2-way valve and valve motor, HERU®130 S EC . . . . .	.8010035
Heating coil, 5 kW incl. 3-way valve and valve motor, HERU®130 S EC . . . . .	.8010036
Heating coil, 5 kW incl. 2-way valve and valve motor, HERU®180 S EC . . . . .	.8010031
Heating coil, 5 kW incl. 3-way valve and valve motor, HERU®180 S EC . . . . .	.8010032
Cooling coil, 2,5 kW incl. 2-way valve and valve motor, HERU®115 T/130 T EC/140 T . . . . .	.8010066
Cooling coil, 2,5 kW incl. 2-way valve and valve motor, HERU®115 T/130 T EC/140 T . . . . .	.8010067
Cooling coil, 2,5 kW incl. 2-way valve and valve motor, HERU®130 S EC . . . . .	.8010037
Cooling coil, 2,5 kW incl. 3-way valve and valve motor, HERU®130 S EC . . . . .	.8010038
Cooling coil, 2,5 kW incl. 2-way valve and valve motor, HERU®180 S EC . . . . .	.8010033
Cooling coil, 2,5 kW incl. 3-way valve and valve motor, HERU®180 S EC . . . . .	.8010034
Floor stand to HERU®130 T EC/140 T . . . . .	.8010056
Bagfilter F5 the same for supply and exhaust air, HERU®90 S EC . . . . .	.1250123
Bagfilter F5 the same for supply and exhaust air, HERU®130 S EC . . . . .	.1250146
Bagfilter F5 the same for supply and exhaust air, HERU®180 S EC . . . . .	.1250134
Extension cord 10 m, cooker hood . . . . .	.6010011

### ELECTRIC DUCT HEATER

HERU has a built-in electrical heater with pulser as standard. When needed the built-in can be replaced with an external heater.

Min. air speed: 1,5 m/s	Efficiency: 5,0 kW	Min. flow 74 l/s
-------------------------	--------------------	------------------

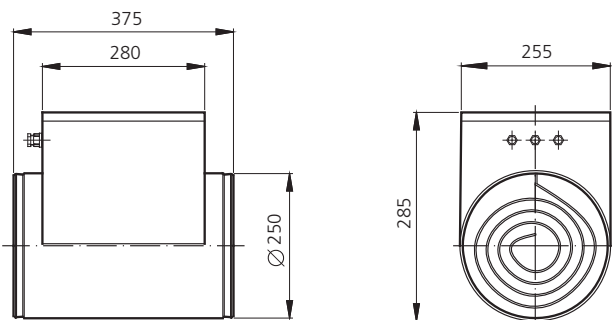

### HEATING COIL (5,0 kW)

#### Air

Flow:	0,20 m³/s
Speed:	2,2 m/s
Temp. in:	10°C
Temp. out:	30,5°C
Efficiency:	5,0 kW

#### Hot water

Flow:	0,10 l/s
Speed:	0,86 m/s
Temp. supply pipe:	60°C
Temp. return pipe:	40°C
Pressure drop:	15,0 kPa

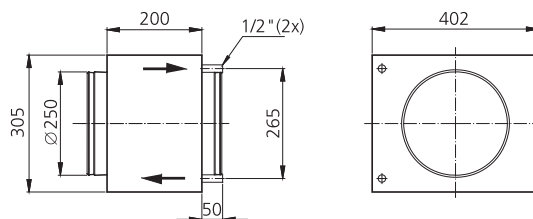

### COOLING COIL (2,5 kW)

#### Air

Flow:	0,20 m³/s	0,15 m³/s
Speed:	2,2 m/s	1,7 m/s
Temp. in:	25°C, 50% Rh	25°C, 50% Rh
Temp. out:	14,4°C	13,5°C
Efficiency:	2,5 kW	2,0 kW

#### Cold water

Flow:	0,16 l/s	0,13 l/s
Speed:	0,8 m/s	0,6 m/s
Temp. supply pipe:	7°C	7°C
Temp. return pipe:	12°C	12°C
Pressure drop:	12,4 kPa	8,8 kPa

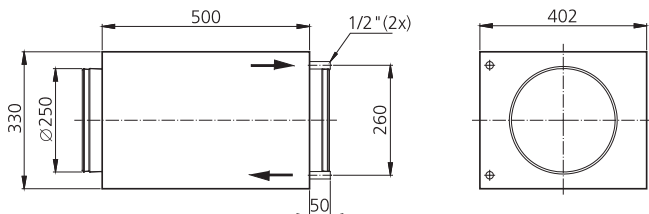

### BATTERY PRESSURE DROP

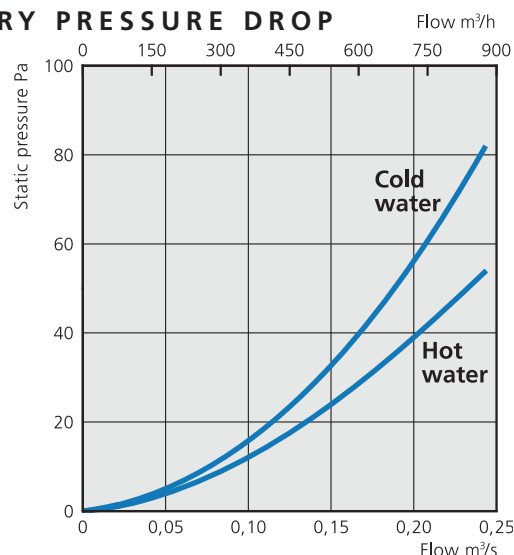

## SPARE PARTS

Rotor motor, complete, HERU®62 T/90 T/90 T EC 2/90 S EC	6000212
Rotor motor, complete, HERU®115 T/130 T EC/140 T/130 S/180 S EC	6000213
Service kit (belt+tightening), HERU®62 T/90 T/90 T EC 2/90 S EC	6000102
Service kit (belt+tightening), HERU®115 T/130 T EC/140 T	6000210
Service kit (belt+tightening), HERU®130 S EC	6000188
Service kit (belt+tightening), HERU®180 S EC	6000189
Filter kit, HERU®62 T/90 T/90 T EC 2	6000205
Filter kit, HERU®115 T/130 T EC/140 T	6000209
Bagfilter-kit F7 the same for supply and exhaust air, HERU®90 S EC	6000211
Bagfilter-kit F7 the same for supply and exhaust air, HERU®130 S EC	6000214
Bagfilter-kit F7 the same for supply and exhaust air, HERU®180 S EC	1250138
Fan kit exhaust air, HERU®62 T	6010022
Fan kit supply air, HERU®62 T	6010021
Fan kit exhaust air, HERU®90 T	6010032
Fan kit supply air, HERU®90 T	6010033
Fan kit exhaust air, HERU®90 T EC 2	6010027
Fan kit supply air, HERU®90 T EC 2	6010028
Fan kit exhaust/supply air, HERU®115 T	6010023
Fan kit exhaust/supply air, HERU®130 T EC	6010027
Fan kit exhaust/supply air, HERU®140 T	6010024
Fan kit, HERU®50 S A2	7710245
Fan kit, HERU®75 S A2	7710246
Fan kit, HERU®90 S EC A2	7710247
Fan kit, HERU®130 S A2	7710248
Fan kit, HERU®130 S EC A2	7710249
Fan kit, HERU®180 S A2	7710250
Fan kit, HERU®130 S EC A2	7710251
Electrical heater, built-in, HERU®50 S/75 S/90 S EC A2	6010133
Electrical heater, built-in, HERU®130 S/130 S EC A2	6010048
Electrical heater, built-in, HERU®180 S/180 S EC A2	6010134
Capacitor HERU®62 T/50 S	4030077
Capacitor HERU®115 T/75 S	4030078
Capacitor HERU®90 T	4030081
Capacitor HERU®130 T/130 S/180 S A2	4030079

Contact your installer/dealer for order.

## ERROR DETECTION

Type of fault	Check...	Remedy
Nothing shows at the display.	...The batteries.	Change the 3 AA batteries.
Can't enter the menus, the keys are locked	...If keylock is activated.	Disable, push the left button down  for 3 seconds.
"Please wait" is displayed.	...That the unit has power. ...The antenna, it should not be mounted against any metal ductwork as this can shield the signal. ...That the wireless control unit is synchronized with the unit.	Wait for 15 minutes. If the message still twinkles, go to next step. Check the fuse, residual current device and connecting. Move the antenna.  See page 105.
The unit does not start.	...That the unit has power. ...That the set point is "On". ...That the unit is connected correctly. When the electrical supply is turned on the unit starts automatically with a few minutes delay. ...Other alarms.	Check the fuse, residual current device and connecting. See page 96. See page 81-90. See page 78.  See below.
The unit has stopped.	...That the unit has power. ...If alarm is triggered.  ...That the right flow direction is choosed.	Check the fuse and safety switch. Check why the alarm is on. When caused error is resolved, restore alarm. After alarm reset, check so the rotor motor is rotating and the fans spinning. See page 104.
When starting the unit the wireless control unit displays wrong temperature alt. alarm of to low temperature.	...If the unit is installed left or right handed.	Set the flow direction. See page 104.
Filtermätning Can't activate the filter measurement.	...That pressure sensor is installed.	Activate sensor. See page 98.
<u>Other alarms:</u> Filter.	...If filters are dirty. ...If the set time for filter measurement is reached	Change filter. Change filter.
Sensor open.	...Which sensor is triggered, see page 96. ...The menus for heater and regulation mode.	Connection to relay card. If error remains, change broken sensor. Make the right setting for heater and regulation mode. See page 103-104.
Sensor shorted.	...Which sensor is triggered, see page 96.	Connection to relay card. If error remains, change broken sensor.
Rotor stop.	...The Function of rotor, rotor motor, rotor sensor and that the rotor belt is intact?	Replace the faulty part.
Overheating.	...If the heat protection of the duct heater is triggered. <i>NB! The unit must be currentless.</i>	Restore the manual overheating protection and reset the alarm.
Low supply air temperature.	...If filters are dirty. ...If the rotor belt slips. ...If the duct heater works. ...That the right flow direction is choosed.	Change filter. Change rotor belt. Ensure function before startup. See page 104.
Low rotor temperature.	...If filters are dirty. ...If the rotor belt slips.	Change filter. Change rotor belt.
Fire alarm.	...Why the fire alarm is triggered.	Ensure function before startup.
Freeze protection.	...There's enough heat to the heating coil.  ...The valve actuator opens as it should.	Ensure function of the heating coil before startup.  Ensure function of the valve actuator before startup.
Motorfel.	...Power to the fans and quick swatches. ...That the impeller is not blocked	Ensure function and change broken fan before startup. Ensure function before startup.
Supply or exhaust air is missing or efficiency too high.	...The air intake. ...Supply and exhaust air filters.	Clean intake grille if dirty. Change filter
Efficiency too low.	...If filters are dirty. ...If exhaust air temperature is low.	Change filter. Check the installation.
Problem when adjusting the air flow.	...That the function for summer cooling is "Off".	See page 103.
Electric heater is not warm.	...If the heater is correct connected. ...That electric heater is "On" in the Service menu.	See page 80. See page 102.

If none of the adjoining information helps to start/clear up the error then contact your electrician/retailer.

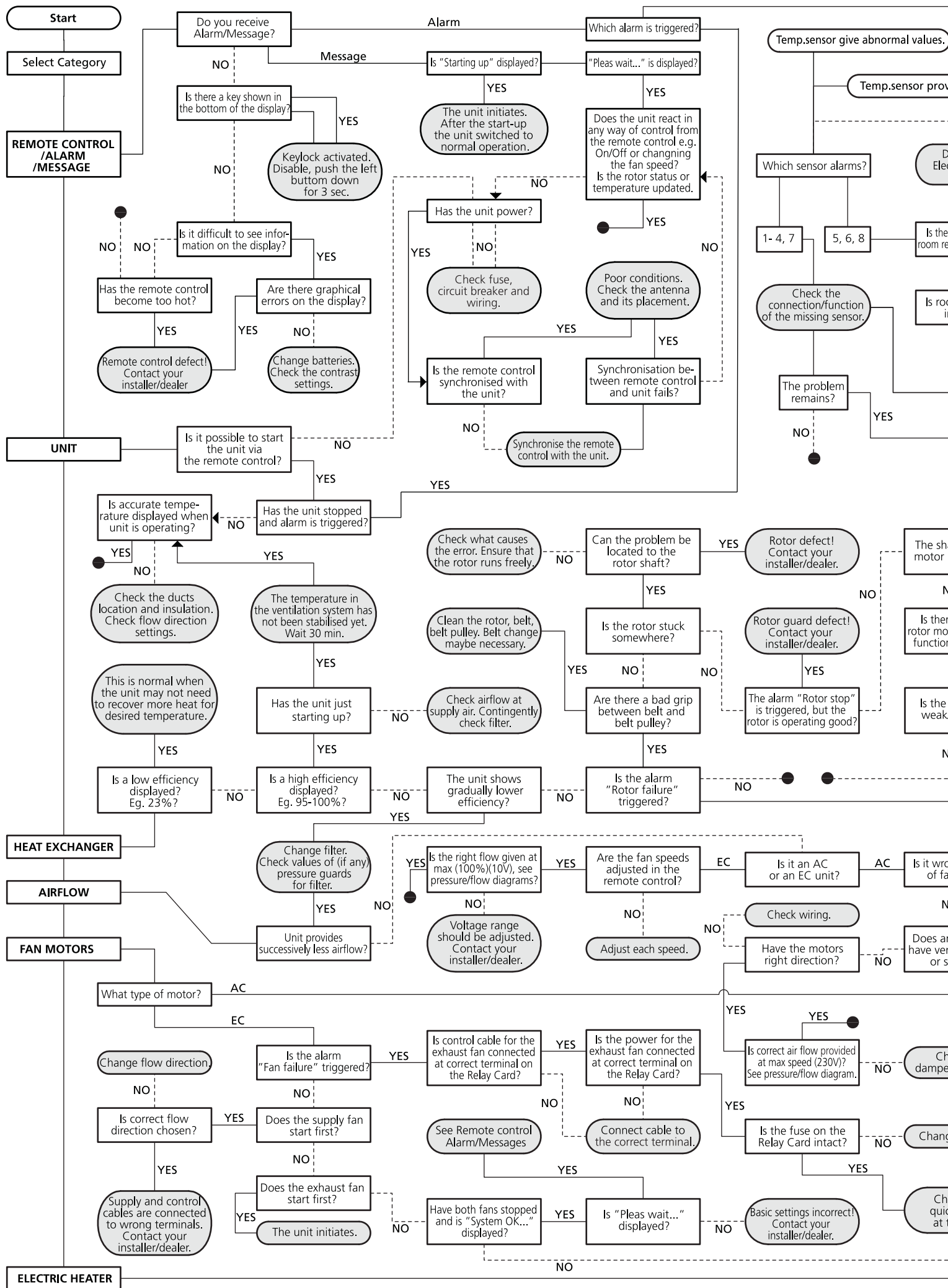



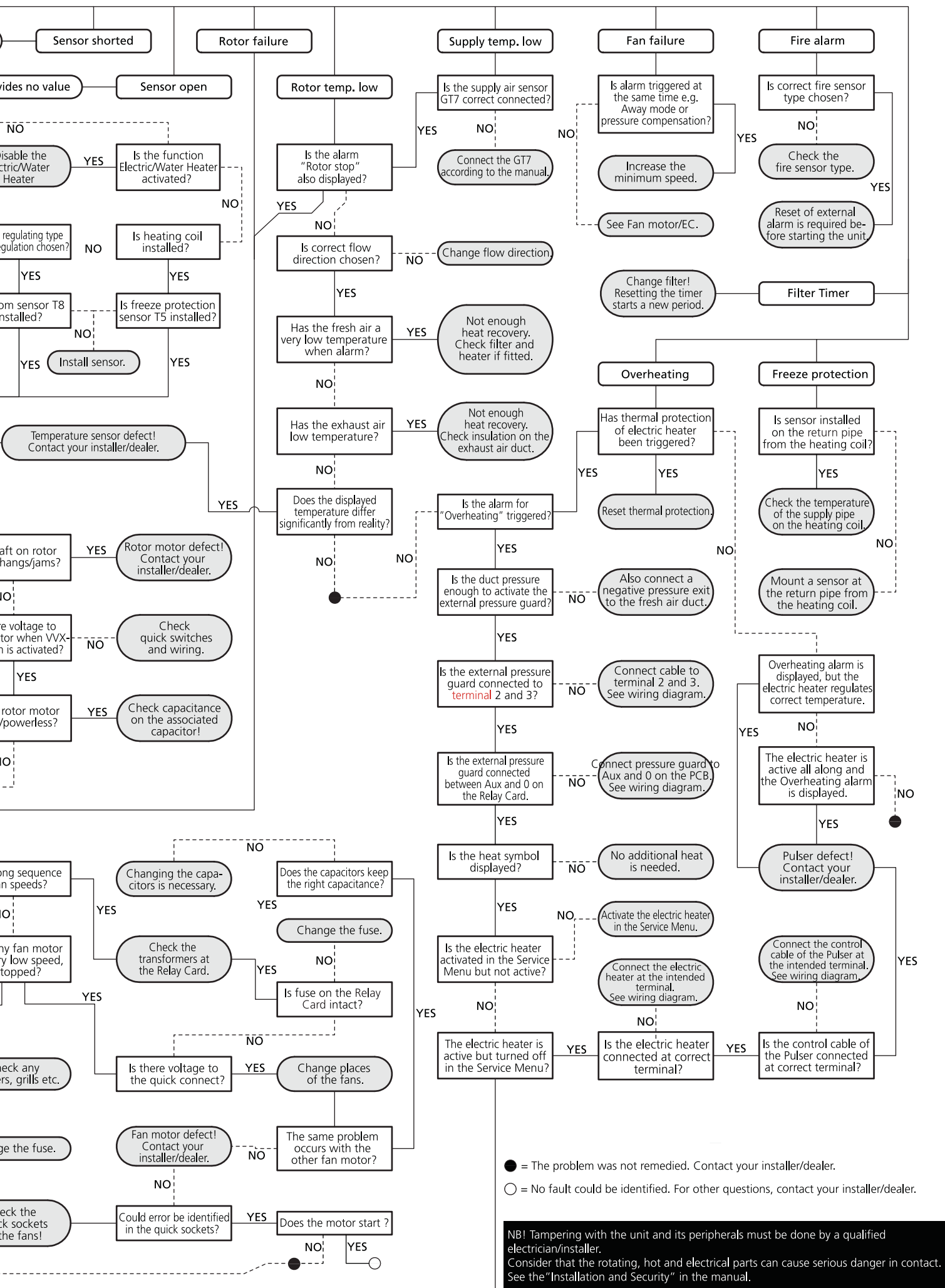

● = The problem was not remedied. Contact your installer/dealer.  
○ = No fault could be identified. For other questions, contact your installer/dealer.

**NB!** Tampering with the unit and its peripherals must be done by a qualified electrician/installer.  
Consider that the rotating, hot and electrical parts can cause serious danger in contact. See the "Installation and Security" in the manual.

# INTERNAL SETTINGS AC

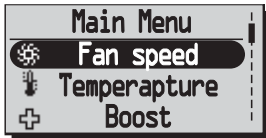

**Fan speed:** .....  
 (min, standard, medium or max.)  
 Default: Std.

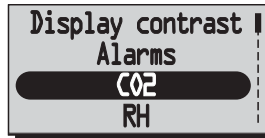

**Limit:** .....  
 (500-1400 PPM) Default: 900 PPM  
**Ramp:** .....  
 (2-200%/h) Default: 50%/h.

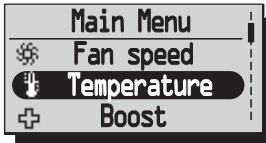

**Temperature:** .....  
 (15°C-40°C)  
 Default : 20°C

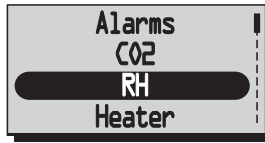

**Limit:** .....  
 (50%-100%) Default: 70%.  
**Ramp:** .....  
 (2-200%/h) Default: 5 min.

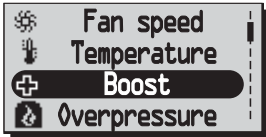

**Time:** .....  
 (10-240 min.) Default: 30 min.  
**Fan:** .....  
 (medium or max) Default: Med.

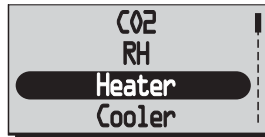

**Electric:** .....  
 (On/Off) Default: Off.  
**Water:** .....  
 ( On/Off) Default: Off.

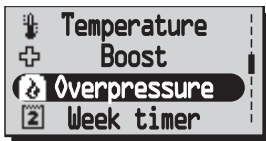

**Time:** .....  
 (5-60 min.)  
 Default : 15 min.

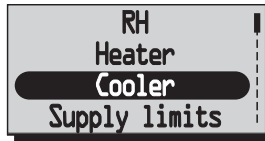

**Cooler:** .....  
 ( On/Off) Default: Off.



**Sensor:** .....  
 (None, SW, -50/+50, 0/100 Pa)  
 Default: None.

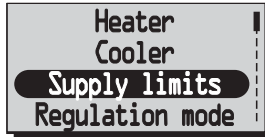

**Min:** .....  
 (15°C-19°C) Default: 15°C.  
**Max:** .....  
 (20°C-40°C) Default: 25°C.

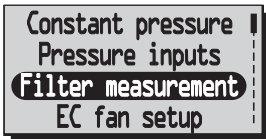

**Filter measurement:** .....  
 (Off/On) Default: Off.

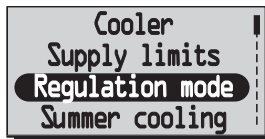

**Regulation mode:** .....  
 (Constant Supply reg./Exhaust reg./Room reg.)  
 Default : Const. supply reg.

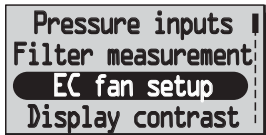

**Fan speed:** .....  
 (Standard, Min, Medium, Max)  
 Default : Standard 30%, Min 20%,  
 Medium 50%, Max 80%.



**InOutDiff:** .....  
 (1°C-10°C) Default: 5°C.  
**Exhaust HI:** .....  
 (19°C-26°C) Default: 24°C.  
**Exhaust LO:** .....  
 (18°C-24°C) Default: 18°C.



**Limit:** .....  
 (5°C-10°C)  
 Default : 10°C.

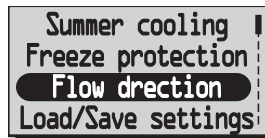

**Flow direction:** .....  
 (Right/Left)  
 Default : Right.

**FILTER CHANGE:** .....

**SERVICE:** .....

# INTERNAL SETTINGS EC

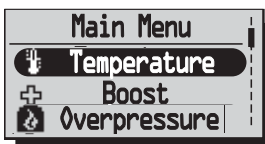

**Temperature:** .....  
 (15°C-40°C)  
 Default : 20°C

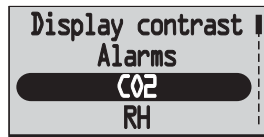

**Limit:** .....  
 (500-1400 PPM) Default: 900 PPM  
**Ramp:** .....  
 (2-200%/h) Default: 50%/h.

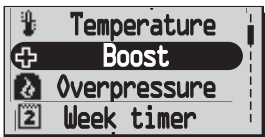

**Time:** .....  
 (10-240 min.) Default: 30 min.  
**Fan:** .....  
 (medium or max) Default: Med.

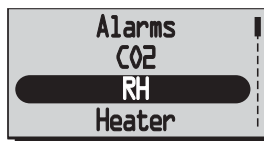

**Limit:** .....  
 (50%-100%) Default: 70%.  
**Ramp:** .....  
 (2-200%/h) Default: 5 min.

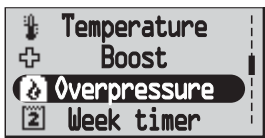

**Time:** .....  
 (5-60 min.)  
 Default : 15 min.

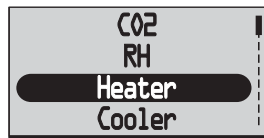

**Electric:** .....  
 (On/Off) Default: Off.  
**Water:** .....  
 ( On/Off) Default: Off.



**Supply:** .....  
 (Pa)  
**Exhaust:** .....  
 (Pa)

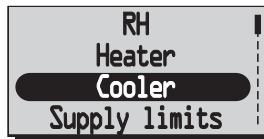

**Cooler:** .....  
 ( On/Off) Default: Off.



**Sensor:** .....  
 (None, SW, -50/+50, 0/100 Pa)



**Min:** .....  
 (15°C-19°C) Default: 15°C.  
**Max:** .....  
 (20°C-40°C) Default: 25°C.

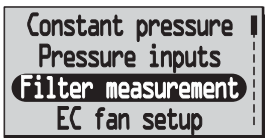

**Speed Inc:** .....  
 (%) Default: 10%.  
**Filter measurement:** .....  
 (Off/On) Default: Off.

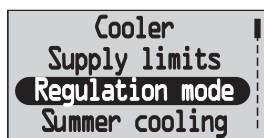

**Regulation mode:** .....  
 (Constant Supply reg./Exhaust reg./Room reg.)  
 Default : Const. supply reg.

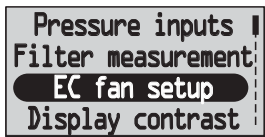

**Fan speed:** .....  
 (Standard, Min, Medium, Max)  
 Default : Standard 30%, Min 20%,  
 Medium 50%, Max 80%.



**InOutDiff:** .....  
 (1°C-10°C) Default: 5°C.  
**Exhaust HI:** .....  
 (19°C-26°C) Default: 24°C.  
**Exhaust LO:** .....  
 (18°C-24°C) Default: 18°C.

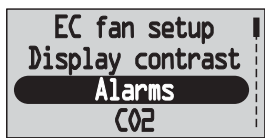

**Limit A:** .....  
 (2°C-10°C) Default: 2°C.  
**Laimit B:** .....  
 (5°C-12°C) Default: 9°C.



**Limit:** .....  
 (5°C-10°C)  
 Default : 10°C.



**Flow direction:** .....  
 (Right/Left)  
 Default : Right.

**FILTERBYTE:** .....  
 .....  
 .....  
 .....

**SERVICE:** .....  
 .....  
 .....  
 .....

# EC DECLARATION OF CONFORMITY

We hereby confirm that HERU®62 T, HERU®90 T, HERU®90 T EC 2, HERU®115 T, HERU®130 T EC, HERU®140 T, HERU®50 S, HERU®75 S, HERU®90 S EC, HERU®130 S, HERU®130 S EC, HERU®180 S and HERU®180 S EC comply with the requirements in the following EU-directives and harmonised standards.

Manufacturer:  
AB C.A. ÖSTBERG  
Industrigatan 2, SE-774 35 Avesta, Sweden  
Tel.No +46 226 860 00  
Fax.No +46 226 860 05  
<http://www.ostberg.com>  
[info@ca-ostberg.se](mailto:info@ca-ostberg.se)  
VAT No SE5563012201



## **Low Voltage Directive (LVD) 2006/95/EG**

### Harmonised standards:

- EN 60335-1:2002 Household and similar electrical appliances - Part 1: General requirements.
- IEC 60335-2-40 Household and similar electrical appliances - Safety  
- Part 2-40: Particular requirements for electrical heat pumps, air-conditioners and dehumidifiers
- IEC 60204-1 edition 5 "Safety of machinery - Electrical equipment of machines - Part 1: General requirements"  
is valid for fans including motor with automatic thermo protector.
- EN 50366 Household and similar electrical appliances - Electromagnetic fields - Methods for evaluation and measurement.

## **Directive for Electromagnetic Compatibility (EMC) 2004/108/EG**

### Harmonised standards:

- EN 61000-6-3: 2007 Electromagnetic compatibility (EMC). Generic standards. Emission standard for residential, commercial and light-industrial environments.
- EN 301 489-3: 2002 Electromagnetic compatibility and Radio spectrum Matters (ERM) - ElectroMagnetic Compatibility (EMC) standard for radio equipment and services part 3 Specific condition for Short-Range Devices (SRD) operating on frequencies between 9 kHz and 40 kHz
- EN 300 220-3:2000-09 Electromagnetic compatibility and Radio spectrum Matters (ERM) - Short Range Devices (SRD) Radio equipment to be used in the 25 MHz to 1000 MHz frequency range with power levels ranging up to 500 mW.

## **Machinery Directive (MD) 2006/42/EG as defined in appendix 2A**

### Harmonised standards:

- ISO 12100-1 edition 2 Safety of machinery - Basic concepts, general principles for design  
- Part 1: Basic terminology, methodology.
- ISO 12100-2 edition 2 Safety of machinery - Basic concepts, general principles for design  
- Part 2: Technical principles.
- ISO 13857:2008 Safety of machinery - Safety distances to prevent hazard zones being reached by upper and lower limbs.
- ISO 14121-1:2007 Safety of machinery - Risk assessment - Part 1: Principles.

Installation must be done in accordance with the attached "Directions for use".

A handwritten signature in black ink, appearing to read 'Stefan Viberger', written over a horizontal line.



**AB C.A. ÖSTBERG**

Industrigatan 2, SE-774 35 Avesta, Sweden

Tel: +46 226 860 00. Fax: +46 226 860 05

Email: [info@ca-ostberg.se](mailto:info@ca-ostberg.se)

[www.ostberg.com](http://www.ostberg.com)